



calma.



pas de murs.  
pas d'horloge.  
pas de wifi.  
avec Calme.



no walls.  
no time.  
no wifi.  
just Calma.







*Calma est une marque de mobilier d'extérieur contemporain basée sur la Costa Brava.*



## NOVEDADES / NEWS

|           |   |    |
|-----------|---|----|
| arena     | alfombra/carpet                         | 7  |
| om wood   | parasol/umbrella                        | 11 |
| masia     | alfombra/carpet                         | 17 |
| lotus     | lámpara de piscina/pool light           | 23 |
| cuina     | alfombra/carpet                         | 26 |
| fang      | alfombra/carpet                         | 30 |
| maca      | hamaca/deck chair                       | 35 |
| normal    | lámpara cerámica/ceramic light          | 38 |
| tub Y     | lámpara cerámica/ceramic light          | 46 |
| boomerang | sillón relax/relax armchair             | 49 |
| bolet     | taburete-mesa compañía/stool-side table | 52 |
| lou       | conjunto relax/relax group              | 58 |
| coqueta   | sillón relax/relax armchair             | 64 |

## GENERAL

|               |   |     |
|---------------|---|-----|
| dorm          | sofá modular/modular armchair           | 72  |
| pepa          | silla-sillón relax/chair-relax armchair | 78  |
| om            | parasol/umbrella                        | 86  |
| nua           | sillón relax/relax armchair             | 94  |
| circus        | set de mesas compañía/side table set    | 99  |
| lola          | silla/chair                             | 103 |
| alat alu      | sofá lounge/lounge sofa                 | 106 |
| alat modular  | sofá lounge/lounge sofa                 | 114 |
| alat wood     | sofá lounge/lounge sofa                 | 117 |
| alat day-Bed  | cama/bed                                | 120 |
| llum          | lámpara/light                           | 125 |
| xica&xanca    | lámpara/light                           | 130 |
| marea         | butaca/armchair                         | 133 |
| marea swing   | columpio/swing                          | 136 |
| trama & malla | cerámica modular/modular ceramic        | 140 |
| trama wood    | sillón/armchair                         | 146 |
| angle         | mesa/table                              | 152 |
| ten           | mesa/table                              | 157 |

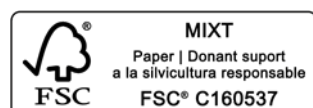







arena







*Tapis  
Polypropylène  
100% recyclé.*

Le tapis Arena “vole” un morceau de crique de la Costa Brava pour que vous puissiez en profiter où vous voulez. Il reproduit subtilement le dégradé de couleurs que subit le sable de la plage lorsqu’il est baigné par l’eau. Tissé à la main et fabriqué à partir de bouteilles 100% recyclées, il convient à la fois pour une utilisation intérieure et extérieure. Le traitement minutieux de ses filaments est dû à l’origine du matériau, qui a une finition complètement organique.

Une invitation de la Costa Brava à laquelle il faudrait répondre au quotidien.

*100% recycled  
polypropylene  
rug*

The Arena rug “steals” a piece of cove on the Costa Brava so you can enjoy it wherever you prefer. Subtly reproduces the color gradient that the sand of the beach suffers when it is bathed by water.

Handwoven and made from 100% recycled bottles, it is suitable for both indoor and outdoor use. The meticulous treatment of its filaments means that the origin of the material is not perceived, which has a completely organic finish.

An invitation to enjoy the Costa Brava every day.



*Le tapis est tissé à la main avec un tissu en polypropylène 100% recyclé, qui provient de bouteilles en plastique.*

Hand-braided with 100% recycled polypropylene fabric, which comes from plastic bottles.









om wood



# om wood | CONÇU PAR ANDREU CARULLA



## *En souvenir de la Méditerranée*

Inspiré des auvents et parasols méditerranéens classiques, OM donne un tournant vers un produit bien établi. Grâce à son mécanisme innovant déplié, le parasol s'adapte à tous les besoins, qu'il soit entièrement ouvert, à moitié ouvert ou à peine ouvert, fournissant différents types d'ombre à chaque position.

## *Evoking the Mediterranean*

Inspired by classic mediterranean canopies and umbrellas, Om brings a twist on a well-established product. Because of its innovative unfolding mechanism, the umbrella can be adapted to any need, whether it is fully, half or hardly open, providing different types of shade for every position.



reddot award 2015  
best of the best







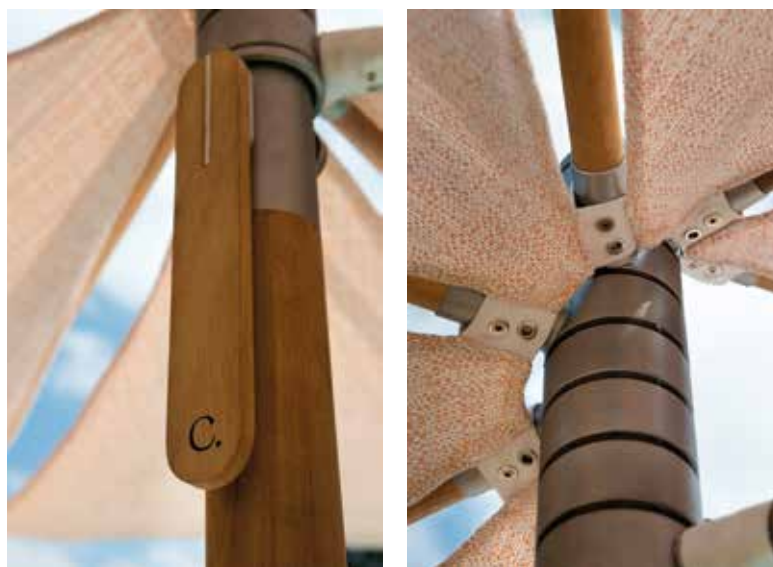

## *Parasol*

Manche et tiges en bois d'iroko. Anneaux de mécanisme en acier inoxydable 304 solide, avec des joints et des rondelles en plastique sur tous les joints. Mécanisme d'ouverture/fermeture en acier inoxydable 304 et bois d'Iroko.

Tissu acrylique Agora.

---

## *Umbrella*

Mast and ribs made from iroko wood.

Mechanism rings made from machined solid stainless steel 304 with plastic gaskets and washers in every joint.

Open/close mechanism in stainless steel 304 and Iroko wood.

Agora acrylic fabric.











masia



*Tapis  
polypropylène  
100% recyclé*

Le tapis Masia reproduit le motif des carreaux de céramique classiques d'adobe qui sont utilisés dans les fermes et les maisons rustiques de l'Empordà et dans une grande partie de la Catalogne. Ce modèle appartient à la vie et à l'esthétique de l'Empordà à la fois dans les environnements des espaces aussi bien rustiques que contemporains.

Adapté à une utilisation intérieure et extérieure, il est fabriqué à la main avec du polypropylène 100% recyclé à partir de bouteilles usées.

*100% recycled  
polypropylene  
rug*

The Masia Carpet reproduces the pattern of the classic ceramic adobe tiles used in farmhouses and rustic homes in the Empordà and much of Catalonia.

This pattern belongs to Empordà life and aesthetics both in rustic environments and in totally contemporary spaces.

Suitable for indoor and outdoor use, it is made by hand with 100% recycled polypropylene from used bottles.





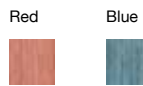

Polypropilene 100% recycled

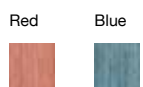

Polypropilene 100% recycled





CALMA. est un chemin qui se parcourt avec simplicité.

---

Simplicity is a path that is travelled with Calma.



lotus



# lotus | CONÇU PAR PETE SANS



## *Lampe de piscine flottante*

Lotus transforme l'eau en lumière. Durant les chaudes nuits d'été, elle offre l'expérience presque magique de se plonger dans une lumière liquide.

Le point d'où émane la lumière est presque imperceptible car elle utilise l'eau pour la diffuser de manière homogène. Lotus essaie d'être invisible, de conquérir l'eau avec sa lumière chaude et subtile.



Lotus transforms water into light. On warm summer nights, it offers the almost magical experience of immersing yourself in liquid light.

The point from which light emanates is almost imperceptible, using water to spread it homogeneously. Lotus tries to be invisible, conquering the water with its warm and subtle light.

## *Floating pool lamp*





### *Lampe murale*

Lampe de piscine flottante, avec socle liège compacté D400, qui intègre une ampoule IP65 avec batterie rechargeable induction (incluse) sans câbles externe Livré avec support mural, à conserver après une utilisation normale.



Floating pool lamp, with a D400 compacted cork base, which incorporates an IP65 bulb with induction charging battery (included) without the need for external cables. Supplied with wall mount, to store after normal use.

### *On the wall*







cuina

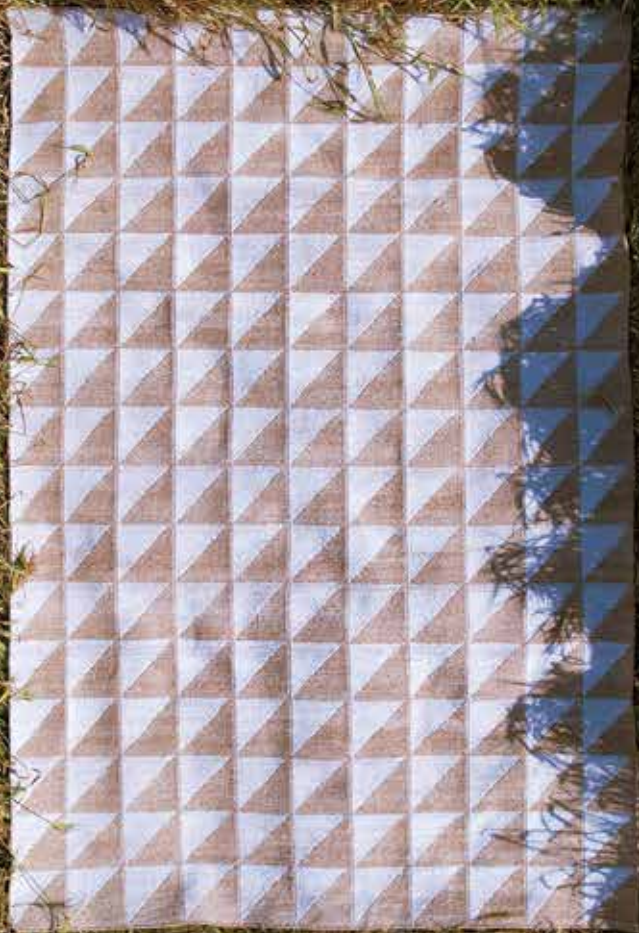





## *L'âme de l'Empordà*

Les tapis de la collection CUINA s'approprient les éléments des traditionnels carrelages des cuisines de l'Empordà, carrés et vitrés avec deux triangles de différentes couleurs qui sont disposés en différentes orientations et modèles, afin de créer des textures variées géométriques que nous reproduisons sur les tapis.

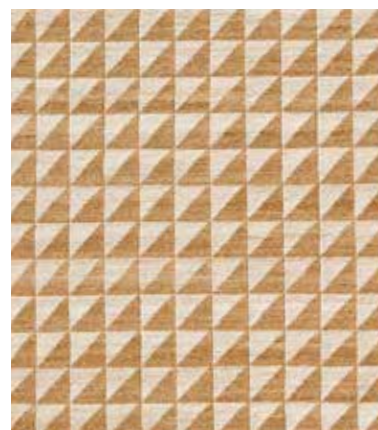

## *Empordà soul*

The CUINA collection rugs appropriate the elements of the traditional Empordà kitchen tiles, square and glazed with two triangles of different colors that are arranged in different orientations and patterns, creating textures of varied geometries that we reproduce on the carpets.











fang







### *La tradition*

Les tapis FANG s'inspirent des artisans catalans, dont le but est de renouveler une finition traditionnelle de la céramique de l'Empordà. Une des extrémités de la pièce en céramique est trempée dans de la glaçure pour donner un point de couleur (et de protection).

Nous répétons cette tradition, symboliquement, dans les tapis de tissus recyclés « trempant » une des extrémités du tapis, parvenant à capturer un geste ancestral, subtil et minimaliste.

---

FANG carpets are inspired by catalan artisans as we renew a traditional finish of Empordà ceramics. One end of the ceramic piece is dipped into enamel to give a point of color (and protection) to the pitcher, clay jug or pot.

We repeat this tradicion, symbolically, on the carpets of recycled fabrics "soaking" in color one of the ends of the carpets, managing to capture an ancestral, subtle and minimal gesture.

### *The tradition*





Plongez vos pieds dans le sable et perdez-vous dans la beauté de la mer, c'est Calma.

---

Sink your feet into the sand and lose yourself in the beauty of the sea, that's Calma.



maca





*Evoquant la  
Méditerranée*

La chaise longue Maca est un classique raffiné. Son esthétique s'intégrera dans n'importe quel espace extra-atmosphérique, donnant une note de joie et de qualité sans tomber dans la stridence.

Son tissu unique est fabriqué selon la tradition de l'artisanat catalan au sud de la France. Les Toiles de Soleil, fondées en 1897, continuent d'utiliser les mêmes techniques et est reconnue comme une entreprise française du patrimoine vivant.

*Evoking the  
Mediterranean*

The Maca deck chair is a refined classic. Its aesthetics will integrate into any outdoor space, giving a note of joy and quality without falling into stridency. Its unique fabric is made following the tradition of Catalan artisanal from the south of France. Les Toiles de Soleil, founded in 1897, continues to use the same techniques and is recognized as a French Living Heritage Company.







### MACA

Bain de soleil avec structure en bois d'iroko, avec accessoires en acier inoxydable et laiton, et fini avec du tissu Sunbrella acrylique ou coton de la prestigieuse marque Les Toiles du Soleil.

### MACA

Iroko wooden frame lounger, with stainless steel and brass accessories, and finished with Sunbrella acrylic fabric or cotton from the prestigious brand Les Toiles du Soleil.







normal



# normal | CONÇU PAR ANDREU CARULLA



## *Couvert intérieur et extérieur*

Les lampes NORMAL recherchent la forme essentielle en simplifiant la géométrie et le matériau. Son esthétique classique et basique contraste avec le matériau inhabituel et rustique mais en même temps sophistiqué.

Une collection entièrement réalisée dans l'Empordà avec des céramiques émaillées de La Bisbal.

La collection est composée de 5 modèles : un sans fil, trois plafonniers et une applique qui nous permet d'éclairer en permanence plusieurs espaces. Son utilisation est recommandée à l'intérieur et couverte à l'extérieur.

## *Indoor and outdoor covered*

NORMAL lamps seek for the essential form by simplifying geometry and material. Its classic and basic aesthetic contrasts with the unusual and rustic but at the same time sophisticated material.

A collection made entirely in the Empordà with glazed ceramics from La Bisbal.

The collection consists of 5 models: one wireless, three ceiling and a wall sconce that allows us to consistently illuminate multiple spaces. Indoor and covered outdoor use is recommended.







Lampe avec une structure en céramique qui intègre une LED de 2,6 W de 315 lumens, un allumage "one" touch et une recharge USB incluse. Elle convient pour l'extérieur.

Ceramic structure lamp that incorporates LED 2,6w of 315 lumens, "one" touch ignition and USB recharge included. Suitable for outdoors.









NORMAL



Applique murale en céramique, intègre une LED de 4,5 W de 500 lumens, installation par câble. Elle est Adaptée à l'extérieur.

---

Ceramic wall light, incorporating LED 4,5w of 500 lumens, wired installation. Suitable for outdoor



CEILING LAMP /PLAFONNIER (2 TAILLES / 2 SIZES)

---



Plafonnier en céramique, avec suspension directe par câble et installation par câble. Il intègre une LED 4.5w de 500 lumens. Adapté à l'extérieur.

---



Ceiling hanging ceramic lamp, with direct suspension by cable and wired installation. It incorporates one LED 4,5w of 500 lumens. Suitable for outdoor

Plafonnier en céramique, avec suspension directe par câble et installation par câble. Il intègre une LED 4.5w de 500 lumens. Adapté à l'extérieur.

---



Ceiling hanging ceramic lamp, with direct suspension by cable and wired installation. It incorporates one LED 10 w of 1.000 lumens. Suitable for outdoor





Plafonnier suspendu en céramique, à suspension directe, installation de câbles et de câbles. Il intègre une LED de 8,4w de 960 lumens. Il peut être utilisé à l'extérieur.

Ceiling hanging ceramic lamp, with direct suspension by cable and wired installation. It incorporates one LED 8,4w of 960 lumens. Suitable for outdoor







# tub Y

CONÇU PAR ANDREU CARULLA



LAMPE / LIGHT BULB

---



La lampe pour le sol comme balise de signalisation, finition en céramique émaillée, 3 W puissance et 150 lumens et 3000K de couleur. Installation directe sur le réseau. La collection NORMAL fabriquée entièrement à l'Empordá avec des émaux céramiques de La Bisbal.

---

Floor lamp as a signaling beacon, in ceramic enamel finish, 3 W of power, 150 lumens and 3000K color. Plug in to the net. From the NORMAL collection made entirely in the Empordá with ceramic glazes from La Bisbal.







boomerang



# boomerang | CONÇU PAR ANDRÉ RICARD



## *Fauteuil relax avec repose- pieds*

Le BOOMERANG est un fauteuil relax avec repose-pieds. Une chaise qu'André Ricard conçoit et édite une petite série en 1952. Aujourd'hui Calma récupère ce design vintage pour sa qualité et son confort. L'élément "boomerang" est celui qui supporte l'assise et le dossier, en plus de donner à la chaise sa propre personnalité. Le dossier a un dispositif interne qui permet de faire varier l'inclinaison naturellement pour l'adapter aux postures les plus confortables et ergonomiques requises.

## *Relax chair with footrest*

The BOOMERANG is a relax armchair with footrest. A chair that André Ricard designed and edited in a small series in 1952. Today Calma recovers this vintage design for its quality and comfort.

The "boomerang" element is what supports the seat and backrest, in addition to giving the chair its own personality. The backrest has an internal device that allows the inclination to be varied naturally to adapt it to the most comfortable and ergonomic postures required.







Tous ses éléments : autant la pièce “boomerang” que l’assise, dossier et pieds, sont en bois de chêne de couleur naturel protégé par un vernis transparent adapté. L’assise et le dossier sont constitués d’une structure en bois recouverte avec un tressage manuel de corde en polymère cellulosique recyclé en couleur naturelle. Un cadre en acier inoxydable laqué relie le cadre en bois et les quatre pieds. Le repose-pieds qui s’adapte à la largeur de l’assise, est une réplique réduite du fauteuil avec les mêmes spécifications techniques.

*Le BOOMERANG est un meuble pour l’intérieur et l’extérieur.*

All its elements: both the “boomerang” piece, as well as the seat, backrest and legs, are made of natural-colored oak wood protected by a suitable transparent varnish. Seat and back are made up of a wooden frame covered with a manual braiding of recycled cellulose polymer rope in natural color. A lacquered stainless steel frame connects the wooden structure and the four legs. The footrest that adapts to the width of the seat, is a reduced replica of the armchair with the same technical specifications.

*The BOOMERANG is a furniture for both indoors and outdoors.*







bolet





# bolet | CONÇU PAR ANDRÉ CARULLA



## *Tabouret pour l'extérieur en céramique*

Bolet est à la fois un exercice de fonctionnalisme et une ode à l'artisanat.

La géométrie Bolet est obtenue par une simple transformation du processus d'extrusion d'argile. Ce qui le rend utile comme tabouret et table d'appoint occasionnelle. Cuit au feu élevé, il est capable de résister à des changements extrêmes de température, ce qui le rend idéal pour une utilisation intérieure et extérieure. Émaillé par immersion dans des couleurs traditionnelles de la Bisbal, la dureté de sa matière est adoucie par une base généreuse en liège naturel et trois trous au sommet offrent un moyen confortable de le déplacer facilement.

Utilitaire, local et chaleureux. Bolet incarne une nouvelle approche d'un processus traditionnel.

## *Glazed ceramic outdoor stool*

Bolet is both an exercise in functionalism and an ode to craftsmanship. The geometry of Bolet is achieved with a simple transformation to the clay extrusion process. Making it useful as both a stool and occasional side-table. Fired at a high heat, it is able to withstand extreme changes in temperature making it ideal for both indoor and outdoor use. Dip-glazed in traditional La Bisbal colours, the hardness of its material is softened with a generous natural cork base and three holes on top provide a convenient way of moving it with ease.

Utilitarian, local and warm. Bolet embodies a new approach to a traditional process.







## *Bolet*

Bolet est un tabouret/table d'appoint en céramique traditionnelle, trempée à 1070°C au four. Il résiste aux changements de température plus abrupte et capable de résister à des climats extrêmes. Il existe en plusieurs couleurs d'émail traditionnel.

---

## *Bolet*

Bolet is a stool/occasional side table made from traditional ceramic, hardened at 1070°C in the kiln, Bolet is resistant to the harshest changes in temperature and is able to withstand extreme climates.

It comes in various traditional glaze colours.













lou







*Ensemble  
de collection  
pour la  
détente.*

Lou est le résultat de la première collaboration entre le studio d'Inma Bermúdez et Calma. La collection est composée de quatre pièces: un pouf, un fauteuil, un canapé et brasier. Nous aimons les appeler des meubles "mous". Le coussin de l'assise est composé de plusieurs couches de viscoélastique, ce qui le rend très confortable. Lorsqu'il prend sa retraite pour les mois d'hiver, Lou conserve toujours une apparence sculpturale en raison de son cadre en tige délicatement léger.

*Relaxed  
soft-furniture  
collection*

Lou is the result of the first collaboration between the studio of Inma Bermúdez and Calma. The collection comprises four pieces: a pouf, a lounge chair, a sofa and a firepit. We like to call them "soft" furniture. The seat cushion is made from various layers of viscoelastic, making it remarkably comfortable. When removed during the winter months, Lou still retains a sculptural appearance due to its delicately light wire frame.





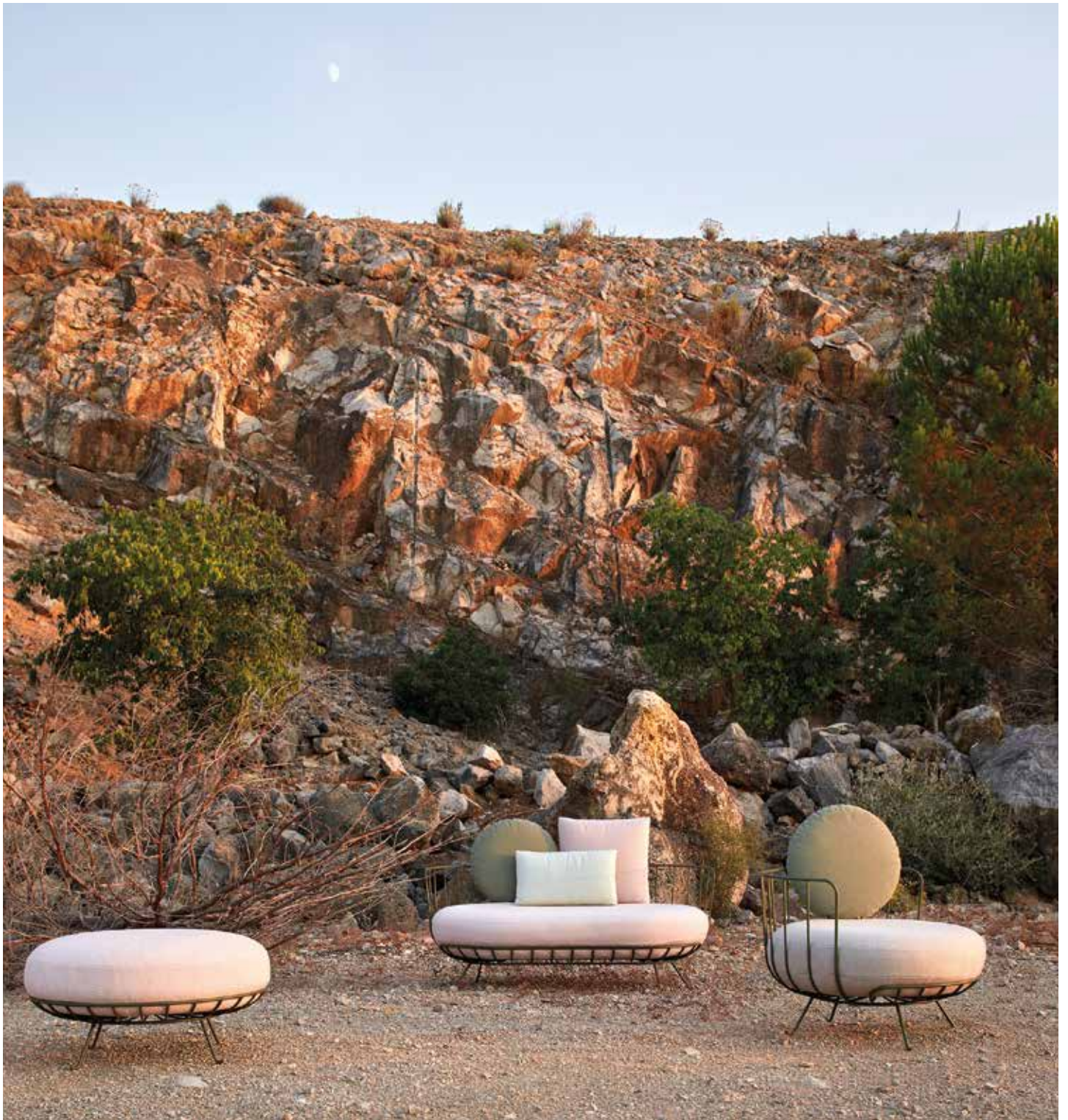



LOU

C'est une collection complète pour la détente, composée d'un fauteuil, d'un canapé 2 places, d'un pouf, d'une table basse et d'un brasero.

La structure est en tige d'acier solide, avec une protection préalable en zinc et peinte avec de la peinture en poudre. Les coussins d'assise sont constitués d'une combinaison de mousses de confort, avec une housse intérieure imperméable en tissu technique et coutures thermoscellées, et une housse extérieure en tissu acrylique Agora, de différentes couleurs. La collection est accompagnée de coussins décoratifs supplémentaires.

---

LOU

This is a complete collection for relax , composed of armchair, 2 seater sofa, pouf, coffee table and brazier.

The structure is made of solid steel rod, with previous protection of zinc and powder coated painted.

The seat cushions are formed by a combination of comfort foams, with an inner waterproof cover of technical fabric and heat-sealed seams, and an outer sheath confection with Agora acrylic fabric, in different colors. The collection is accompanied by additional decoration cushions.





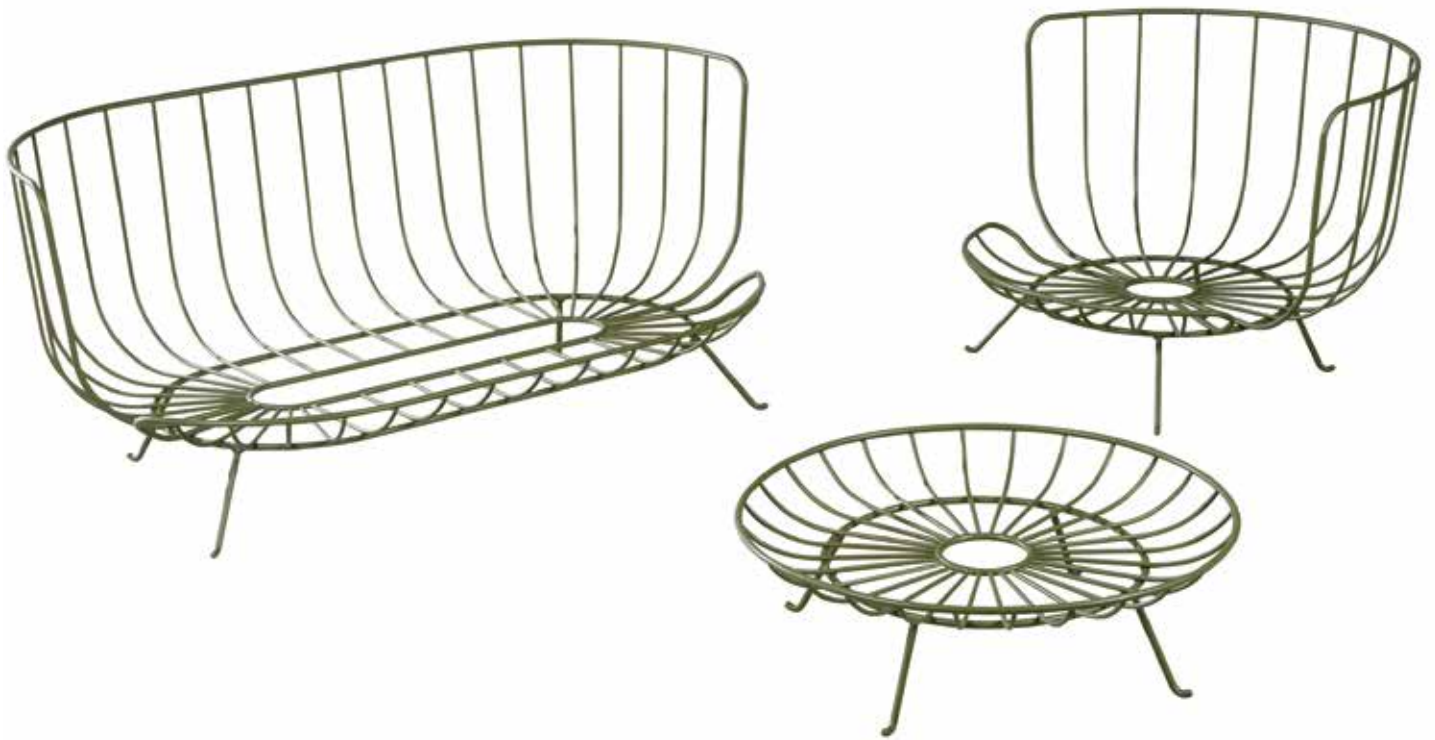









coqueta



# coqueta | CONÇU PAR PETE SANS



## *Un fauteuil tissé en osier.*

Calma a sauvé l'un des grands classiques du design espagnol pour sa nouvelle collection. Récompensé par un prix Gold Delta en 1989, le prix pour design le plus convoité du pays, la chaise Coqueta de Pete Sans est une pièce de design soigneusement équilibré et radical. Une étape importante dans l'histoire du design espagnol, un siège de vannerie est suspendu à sa structure en acier inoxydable sans soudure, le tout maintenu dans ses moindres détails identifiables : une ceinture à boucle qui court le long de la selle.

## *A woven wicker armchair*

Calma has rescued one of Spain's great design classics for its new collection. Bestowed with a Gold Delta Award in 1989, the country's most coveted design award, the Coqueta chair by Pete Sans is both a carefully balanced and a radical piece of design. A milestone in the history of Spanish design, a basket-weave seat is suspended from its seamless stainless steel structure, all of which is held together with its most identifiable detail: a buckled belt which spans the length of the chair.













COQUETA

Un classique du design dans l'histoire du design espagnol, ce fauteuil se caractérise par son assise de panier tressé qui est suspendu à une structure en acier inoxydable. Ces composants sont structurellement renforcés par une ceinture à boucle qui s'étend sur toute la longueur de la chaise, fournissant une tension.

Tressé à la main avec de la moelle naturelle.

---

COQUETA

A design classic in the history of Spanish design, this armchair is characterised by its woven basket seat that is suspended from a stainless steel frame. These components are structurally strengthened by a buckled belt that spans the length of the chair, providing tension.

Hand braided with natural pith.

















dorm



*Un canapé  
d'extérieur  
modulaire*

Conçu pour être une collection discrète et fiable.  
Mobilier 100% outdoor, modulable et polyvalent grâce  
à sa simplicité. Rembourrage amovible avec protection  
imperméable de ses mousses intérieures confortables.

*A soft-modular  
outdoor sofa*

Designed to be a discreet and reliable collection of 100%  
outdoor furniture, modular and versatile due to its simplicity.  
Removable upholstery with waterproof protection for its  
interior comfort foams.







Un simple changement de direction du support métallique en forme de "U", permet les 3 compositions: extension, chaise longue et canapé.

A simple change of direction of the "U" shaped metal support allows 3 compositions: extension, sofa and chaiselongue.



#### CANAPÉ MODULAIRE

Dorm est une collection de canapés modulaires recouverts d'une structure interne en polyéthylène 100% recyclable par roto moulage. Ses coussins sont fabriqués avec une combinaison de mousses techniques pour un maximum de confort et protégé par un tissu imperméable amovible. Chaque module est séparé par une structure en acier inoxydable qui permet le drainage entre le dossier, le coussin de siège et accoudoir. Les pieds sont en acier inox poli brillant.

#### MODULAR SOFA

Dorm is a collection of upholstered modular sofas with an internal structure made from rotation-moulded 100% recyclable polyethylene. Its cushions are made from a combination of technical foams for maximum comfort and protected by a removable waterproof fabric. Each module is separated by a stainless steel structure that permits drainage between backrest, seat cushion and armrest. The feet are in stainless steel polished to a high shine.







Couvertures d'hibernation / winter covers







pepa







*Un système  
de types de  
sièges origami  
incroyablement  
flexible.*

Différentes combinaisons de matériaux et de cadres définissent la Collection de assises Senyora Pepa. Les housses peuvent être retirées et changées en un instant.

Tout un chacun, avec sa propre personnalité, peut se sentir l'aise, à l'intérieur comme à l'extérieur, profiter du soleil méditerranéen ou se réchauffer près du chauffage au feu de bois.

*An origami-like  
seating system  
that is  
incredibly  
flexible.*

Different material and frame combinations define the Senyora Pepa seating collection. The covers can be removed and changed in an instant.

Each with its own distinctive personality, they can easily feel at home indoors and outdoors, enjoying the Mediterranean sun or keeping warm by a wood-burning stove.







#### FAUTEUIL EMPILABLE

La structure est formée de tiges d'acier de 12 mm qui sont pliées pour se rencontrer tangentiellement. Soigneusement soudé par points, cela minimise le nombre de joints. Galvanisé puis thermolaqué au four, cela lui confère une protection antioxydante.

Là où la structure rencontre le sol, les coins arrondis sont protégés par des pieds en nylon.

L'assise et le dossier mesurent 65 cm de large en tissu acrylique avec rembourrage amovible. Coussins en tissu acrylique avec coutures thermosoudées.

---

#### STACKABLE LOUNGE CHAIR

The structure is formed by 12mm steel rods that are bent to meet tangentially. Carefully spot-welded, this minimises the amount of joints. Galvanised and then powder coated in the oven, this gives it an anti-oxidant protection.

Where the structure meets the ground, round corners are protected with nylon feet.

The seat and backrest are both 65cm wide in acrylic fabric with removable padding. Cushions in acrylic fabric with heat-sealed seams.









#### CHAISE EMPILABLE

Les structures sont constituées d'un tube en acier inoxydable de 12 mm de diamètre qui relie les sections droites avec les sections courbes, reliées par une soudure soignée pour minimiser les jointures. La finition est terminée avec une peinture en poudre cuite, après un traitement protecteur antioxydant préalable à base de galvanisation.

Les pieds sont constitués de rayons, tous pareils, qui permettent l'accouplement des butées en nylon avec les formes du rayon du tube et éviter ainsi le contact direct du métal avec la chaussée.

L'assise et le dossier constituent un monobloc de 43 cm de large en tissu acrylique, avec des inserts rembourrés amovibles.

---

#### STACKABLE CHAIR

The structures are made of 12 mm diameter stainless steel tube that connect straight sections with curved sections, joined by careful welding to minimize the joints. The finish is given with the powder paint in the oven, after treatment of antioxidant protection based on galvanized.

The feet are formed by spokes, all equal, which allow the coupling of nylon stops with the shape of the radius of the tube and thus avoid direct contact of the metal with the pavement.

Seat and back of a 43 cm wide piece in acrylic fabrics, with removable padded inserts.













om





*Evoquant la  
Méditerranée*

Inspiré des auvents et parasols méditerranéens classiques, OM donne une nouvelle vision à un produit bien établi. Grâce à son mécanisme innovant déplié, le parasol s'adapte à tous les besoins, qu'il soit entièrement ouvert, à moitié ouvert ou à peine ouvert, fournissant différents types d'ombre à chaque position.

*Evoking the  
Mediterranean*

Inspired by classic mediterranean canopies and umbrellas, Om brings a twist on a well- established product. Because of its innovative unfolding mechanism, the umbrella can be adapted to any need, wether it is fully, half or hardly open, providing different types of shade for every position.



**reddot award 2015**  
best of the best







#### PARASOL

Mât et tiges en aluminium extrudé 6063, anodisé en argent ou noir.

Anneaux de mécanisme en aluminium massif mécanisé 6063 avec joints et rondelles plastiques sur toutes les jointes.

Mécanisme d'ouverture/fermeture en acier inoxydable 304.

Tissu polyester à base de triangles individuels inséré dans la rainure des tiges.

---

#### UMBRELLA

Mast and ribs made from extruded aluminium 6063, anodised in silver or black.

Mechanism rings made from machined solid aluminium 6063 with plastic gaskets and washers in every joint.

Open/close mechanism in stainless steel 304.

Fabric in polyester from Individual fabric panels inserted in the slots of the ribs.

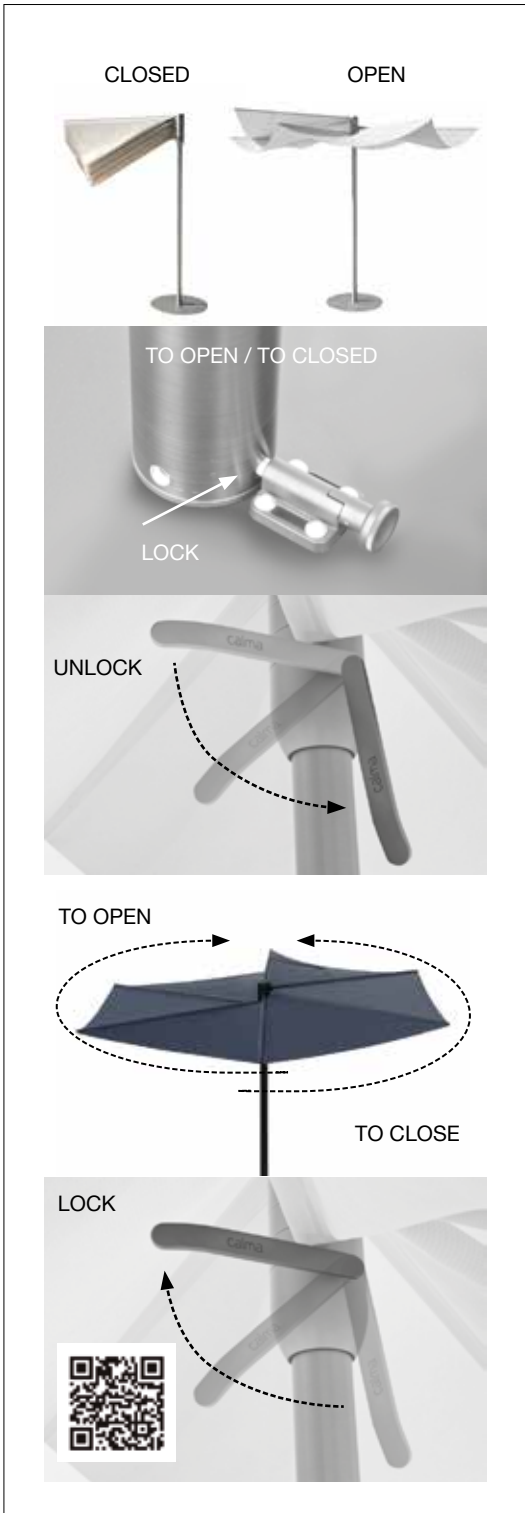

Table réglable en hauteur / Height adjustable table









Ce mécanisme déverrouille la base du mât et permet (en cas de vent fort) que le parasol prenne la direction du vent sans résister et empêcher le parasol de tomber.

This mechanism unlocks the base of the pole and allows (in case of wind) the parasol to take the direction of the wind without resistance and prevents the parasol from falling.

Ouverture et verrouillage de l'ensemble / Opening and blocking of the set











nua





*Imagine-toi*

Avez-vous déjà imaginé qu'un simple tissu pourrait devenir votre canapé relaxant ?

La NUA l'est. Un tissu simple sur une charpente en aluminium.

*Imagine*

Have you ever imagined a simple dress could become your relax sofa? Nua is this. A simple dressed up naked aluminum frame.

Structure tubulaire en acier inoxydable peint au four. Coussins en mousse confort recouvert de tissu acrylique ou couvertures intérieures nautiques et imperméables de protection avec coutures thermosoudées.

Stainless steel tubular structure powder painted. Comfort foam cushions upholstered with acrylic or nautical fabric and waterproof interior protective covers with heat-sealed seams.









circus



# circus | CONÇU PAR ANDREU CARULLA



*Tables  
auxiliaires  
empilables et  
polyvalentes*

Andreu Carulla a conçu la collection CIRCUS. Une collection de tables d'appoint empilables pour marque de mobilier d'extérieur qui complète parfaitement la collection des assises.

*Versatile  
stackable  
sidetables*

After introducing our Senyora Collection, Andreu Carulla has designed Circus. A collection of stackable sidetables for the outdoor furniture brand that complement the seating collection perfectly.











lola





## *Madame Lola*

Lola, populaire, dynamique, courageuse et très pratique, Mme Lola est la femme typique qui semble être la chaise normale, mais au fond elle est différente, à la fois délicate et résistante.

## *Senyora Lola*

Lola, popular, dynamic, courageous and very practical, Sra Lola is the typical lady who seems you have known her your entire life, but inside she is really different. It looks delicate but is very resistant.













alat alu

















---

#### SOFA MODULAIRE

Alat est une collection de canapés aux grandes dimensions.

D'apparence austère, sa forme permet diverses configurations modulaires.

Ses côtés « ailés » offrent à l'utilisateur de multiples formes de s'asseoir ou se coucher.

#### SOFA MODULAR

Alat is a collection of lounge sofas of titanic proportions. Of austere appearance, its shape permits various modular configurations.

Its winged sides give the user multiple ways of sitting or laying down.





# alat modular | CONÇU PAR ANDREU CARULLA



*Un sofa aux  
dimensions  
titaniques*

Alat est une collection de canapés aux grandes dimensions.

D'apparence austère, sa forme permet plusieurs configurations modulaires.

Ses côtés « ailés » offrent à l'utilisateur de multiples formes de s'asseoir ou se coucher.

*A sofa of  
titanic  
proportions*

Alat is a collection of lounge sofas of titanic proportions. Of austere appearance, its shape permits various modular configurations.

Its winged sides give the user multiple ways of sitting or Laying down.







---

#### SOFA MODULAIRE

La structure est en tôle d'aluminium découpé au laser et plié, avec finition peinture en poudre cuite.

Les coussins ALAT sont remplis de mousses de confort de différentes densités, avec une housse de protection étanche dont les coutures sont thermosoudées et une finition extérieure en tissu vinyle technique ou acrylique adapté à l'extérieur.

#### MODULAR SOFA

The structure is made of a laser-cut and folded aluminum sheet, with an oven-baked powder paint finish.

Alat cushions are filled with comfort foams of different densities, with a waterproof protective cover with heat-sealed seams and an outer finish in technical vinyl or acrylic fabric suitable for outdoor use.





alat wood





# alat wood | CONÇU PAR ANDREU CARULLA



*Un sofa aux dimensions titaniques*

ALAT est une simple invitation à s'allonger de façon informelle et audacieuse.

Une proposition de détente sans complexes, provocante par sa forme et ses dimensions.

*A sofa of titanic proportions*

Alat is a simple invitation to lie down informally, a sassy proposal to relax with no complex, provocative because of its shape and dimensions.

www.calmaoutdoor.com







## ALAT WOOD

---

C'est une variante de la collection ALAT présentée en une seule dimension, 350cm de longueur. La structure principale est en bois d'Iroko naturel, sans aucun traitement ni protection.

Les accessoires de construction sont en acier inoxydable et en aluminium.

Les coussins de la collection ALAT sont composés de mousses de confort de différentes densités, recouverts d'une housse intérieure de protection étanche et la housse

extérieure est recouverte de vinyle ou de tissu acrylique.

---

It is a variant of the ALAT collection presented in one dimension, 350cm long.

The main structure is made of natural Iroko wood, without any treatment.

Construction accessories are made of stainless steel and aluminum.

The cushions of the Alar collection are made up of Comfort foams of different densities, covered with a waterproof protective inner sleeve and outer sleeve upholstered with vinyl or acrylic fabric

Aluminium découpé  
au laser et pliage,  
géométries et des trous  
qui laissent passer l'eau.

Laser cut and folded  
aluminium, geometries  
and holes that allow  
residual water to pass  
through.





alat daybed



# alat daybed | CONÇU PAR ANDREU CARULLA



## *Confort épique*

Une évolution du canapé ALAT, le lit de repos ALAT est confortable dans des proportions épiques. Un grand meuble qui abrite avec un paravent de lattes qui couvre tout, le transformant en une alcôve confortable pour une utilisation à l'extérieur.

## *Epic comfort*

An evolution of the award-winning Alat Sofa, the Alat Daybed is comfort at epic proportions. An ample piece of furniture that shelters the user with an all-covering slatted screen, making it a cozy alcove for outdoor use.





## ALAT DAYBED

ALAT DAYBED est une chaise longue double extra-large avec un grand auvent, qui agrandit la famille de la collection ALAT.

Structure en aluminium thermolaqué peint texturé, mesure 280x200x210cm. Tout l'extérieur du Daybed ALAT, est réalisé avec des lattes en bois d'Iroko, fournissant des ombres et des motifs pour la protection solaire.

Les coussins de ce produit sont fabriqués avec des mousses techniques grand confort et protégées par une housse intérieure imperméable avec des coutures thermosoudées.

La finition extérieure est disponible en différents tissus acryliques ou techniques.

## ALAT DAYBED

ALAT DAYBED is a double extra-large lounger with a large canopy, which extends the ALAT collection family.

Structure of aluminum powder coated textured painted, measures of 280x200x210cm. All the exterior of the Daybed ALAT, is made with a blind of Iroko wood, providing shadows and wefts for sun protection.

The cushions of this product are made with high comfort technical foams and protected with an inner waterproof cover of heat-sealed seams. The exterior finish available in different acrylic or technical fabrics

Aluminium découpé au laser et pliage, des géométries et des trous qui laissent passer l'eau.

Laser cut and folded aluminium, geometries and holes that allow residual water to pass through







llum, xica & xanca





*Chaleur  
et confort  
visuel*

Lampe d'extérieur en polyéthylène, qui éclaire dans tous directions, et est suspendu sur trois pieds en bois.

Conçu pour apporter chaleur, confort et lumière à la fois dans des espaces intérieurs et extérieurs.

*Warm and  
visual  
comfort*

Outdoor Lamp made of polyethylene, which illuminates in all directions, and is suspended on three wooden feet. Designed to provide warmth, comfort and light in both indoor and outdoor spaces.





#### LAMPES POUR EXTÉRIEUR

LLUM est la première lampe de Calma. Il est basé sur un ballon en polyéthylène roto moulé, soutenu par 3 pieds de bois d'Iroko adapté à une utilisation en extérieur, et intègre une ampoule LED 4000K. Il existe en 2 hauteurs: 80 et 120 cm

---

#### OUTDOOR LIGHTING

LLUM is Calma's first lamp. It is based on a rotomolded polyethylene balloon, supported by 3 feet of Iroko wood suitable for outdoor use, and incorporates a 4000K LED bulb. It comes in 2 heights: 80 and 120 cm









*Chaleur et  
confort visuel*

Un ballon en polyéthylène givré de couleur naturelle suspendu entre trois pieds en bois d'Iroko. Il fournit de la lumière dans toutes les directions. Conçu pour fournir de la chaleur et de la lumière à l'extérieur, polyvalent et très facilement transportable.

*Warm and  
visual  
comfort*

A frosted polyethylene globe in a natural colour suspended between three Iroko wood legs, providing light in all directions. Designed to provide warmth and light. It's versatile and easy to move.





#### LAMPE EXTÉRIEURE

Ces 2 lampes rejoignent la famille LLUM pour étoffer la collection. La particularité est qu'ils intègrent un luminaire IP65, charge de la batterie par induction sans avoir besoin de câbles externes et d'une ampoule de 290 lumens. L'enveloppe monobloc en polyéthylène roto moulé de couleur naturelle, permet la diffusion de la lumière dans une intensité régulière et proportionnée. La structure se compose de 3 pieds en bois d'Iroko et ils sont disponibles en 2 tailles.

---

#### OUTDOOR LIGHTING

These 2 lamps join the LLUM family to expand the collection. The special feature is that they incorporate an IP65 luminaire, battery powered charge by induction without the need for external cables and a 290 lumen bulb.

The one-piece rotomold polyethylene housing in natural color, allows the diffusion of light in a regular and proportionate intensity. The structure consists of 3 legs of Iroko wood and come in 2 measures.





marea





*Balançoire  
ou chaise*

Solide mais légère, rigide mais libre, MAREA est une collection d'assises défini par l'équilibre délicat et la dualité. Conçu par Andreu Carulla et Joe Doucet, MAREA incarne l'approche de conception particulière de chaque designer dans un meuble unique. Disponible en balançoire et fauteuil, la structure de l'assise est dans les deux cas, suspendue, ce qui donne un doux balancement comme la marée de l'océan.

*swing or  
armchair*

Solid but light, rigid but free, Marea (meaning "tide" in Spanish) is a seating collection defined by delicate balance and duality. Co-designed by Andreu Carulla and Joe Doucet, it embodies each designer's particular design approach in a singular piece of furniture. Available both as a swing and as an armchair, the seat structure is in both cases suspended, giving it a gentle back-and-forth movement just like the tide of the ocean.





#### MAREA

C'est une collection pour la détente, composée de 2 pièces, une « loveseat » de structure en bois d'Iroko naturel sans traitement préalable, et une balançoire conçue pour être suspendue. Ils ont en commun le dossier du siège, de mêmes mesures et motifs, avec une base en tissu technique Batyline Eden en 2 coloris, avec inserts en bois de sapin pour structurer la forme et l'ergonomie.

---

#### MAREA

It is a collection for relax, composed of 2 pieces, a "loveseat" of natural Iroko wood structure without previous treatment, and a swing designed to be suspended.

They have in common the seat-backrest, of the same measures and patterns, based on technical fabric Batyline Eden in 2 colors, with inserts of fir wood to structure the shape and ergonomics.





marea swing





# marea swing | CONÇU PAR ANDREU CARULLA



## *Un repos*

Solide mais légère, rigide mais libre, Marea est une collection de sièges définie par un équilibre délicat et une dualité.

Conçu par Andreu Carulla, il incarne l'approche de conception particulière de chaque créateur dans un meuble unique. Disponible en balançoire et en fauteuil, la structure du siège est suspendue dans les deux cas, ce qui lui donne un doux mouvement de balancement comme la marée de l'océan.

## *A lounging collection*

Solid but light, rigid but free, Marea (meaning "tide" in Spanish) is a seating collection defined by delicate balance and duality. Designed by Andreu Carulla, it embodies each designer's particular design approach in a singular piece of furniture. Available both as a swing and as an armchair, the seat structure is in both cases suspended, giving it a gentle back-and-forth movement just like the tide of the ocean.







#### MAREA SWING

Un meuble conçu pour la détente, avec une structure en bois massif d'iroko, est disponible en deux versions : une version fauteuil et une version balançoire en suspension. Ils partagent une assise et un dossier communs de dimensions égales, en toile technique Batyline Eden bicolore, avec inserts en latte de sapin de Douglas pour structurer ergonomiquement.

---

#### MAREA SWING

A piece of furniture designed for relaxation, with a frame made from solid iroko wood, it is available in two versions: an arm chair and a hanging swing version. They share a common seat and backrest of equal dimensions, made from technical Batyline Eden fabric in two colours, with slatted Douglas-fir inserts to structure it ergonomically.



calma.



trama & malla

calma.



# trama | CONÇU PAR ANDREU CARULLA



*Céramique  
modulaire  
pour  
l'extérieur*

Une réinterprétation de la « célosie » espagnole typique, un élément céramique architecturale modulaire pour l'extérieur. Trama est unique en ce sens qu'il est le premier de son genre qui ne produit pas double épaisseur de paroi lorsqu'il est empilé. Il permet également différents niveaux de transparence selon la manière dont configurer les pièces individuelles.

*Modular  
ceramic  
outdoor*

A reinterpretation of the typical Spanish "celosia", a modular ceramic outdoor architectural feature.

Trama is unique as it is the first in its kind not to produce double-wall thicknesses when built-up. It also allows varying levels of transparency depending on the way the individual pieces are configured.





# malla | CONÇU PAR ANDREU CARULLA



## *Céramique modulaire pour l'extérieur*

Une réinterprétation de la « célosie » espagnole typique, un élément céramique architecturale modulaire pour l'extérieur.

MALLA peut être soutenue sur des tiges structurales et peut être suspendue comme un rideau de céramique.

## *Modular ceramic outdoor*

A reinterpretation of the typical Spanish “celosia”, a modular ceramic outdoor architectural feature.

Malla is able to be supported by structural rods and offers the option to be hung like a ceramic curtain.







*Vous lisez un livre, vous êtes complètement absorbé; mais soudain vous levez tête et vous vous rendez compte que vous ne pourriez pas vous sentir mieux.*

---

*You read a book, you are completely absorbed; but suddenly you raise your head and realize that you couldn't be better*



trama wood





# trama wood | CONÇU PAR SERRAYDELAROCHA



## *Bois d'iroko*

Le défi posé dans la collection TRAMA était double ; devrait être à jour mais en même temps, il fallait qu'elle soit compréhensible par les gens, qu'elle leur soit familière. Pour cela nous avons opté pour l'utilisation du bois, un matériau noble et très répandu dans l'extérieur, en format latte, transmettant un langage familier.

Toute la séquence de lattes espacées nous donne un effet vraiment intéressant, d'ombres et de transparences qui donnent son nom à la collection.

## *Iroko wood*

The challenge posed in the TRAMA collection was twofold; It had to be actual, but at the same time it had to be understandable by people, to be familiar to them. To get this we opted for the use of wood, a noble and very common material abroad, in a slat format, transmitting a familiar language.

The entire sequence of spaced slats gives us a really interesting effect, of shadows and transparencies that give the collection its name







## TEN

Structure tubulaire en acier inoxydable 304, différentes sections, finition naturelle sans aucun traitement, et des lattes en bois Iroko.

Tubular structure in 304 stainless steel, with different sections, natural finish without any treatment, and Iroko wood slats.















angle



# angle | CONÇU PAR SERRAYDELAROCHA



*Comme un  
jeu de plans  
incliné...  
géométrie  
pure*

Angle est une table pour les grands espaces, sculpturale, architecturale, mais en même temps délicate et élégante. Un projet de simplicité apparente, mais dont le travail technique est très détaillé.

*As a game  
of inclined  
planes... Pure  
geometry*

Angle is a table for large spaces, sculptural, architectural, but, at the same time, it is delicate and elegant. A project of apparent simplicity, but which has detailed technical work.







Régulateurs en acier inoxydable pour nivellement au sol.

---

Stainless steel regulators for leveling.

#### TABLEAU

Angle est un exercice de conception où le nouveau matériel a été l'essence et la motivation.

SerraydelaRocha souligne que "sa géométrie a été étudiée au niveau structurel pour atteindre une rigidité maximale de la manière la plus simple, afin d'obtenir un effet visuel de légèreté".

---

#### TABLE

Angle is an exercise of design where the new material has been the essence and the motivation. SerraydelaRocha highlight that "its geometry has been studied at the structural level to get maximum rigidity in the simplest way, achieving a visual effect of lightness".





ten





*L'essence de  
la nature*

Collection de tables à manger, lignes droites et aspect compact, sobre et résistante.  
Convient à différents environnements qui ordonnent et modulent les espaces.

*The essence  
of nature*

Dining table collection with straight lines and a compact appearance. Its design is sober and resistant. It's suitable for different environments helping organize space.





#### TABLE À MANGER

Structure châssis aluminium sur pieds démontables également en aluminium, le tout passé à la peinture en poudre au four. Le plateau est en DEKTON d'une épaisseur de 8 mm.

#### DINING TABLE

Aluminum frame structure on removable legs also of aluminum, all finished with Baked powder paint. Component worktop Dekton, 8 mm thick.









## Andreu Carulla

Grâce à la matérialité, l'artisanat et la durabilité comme objectifs, Andreu Carulla crée de beaux objets avec un attrayant

intemporel. Suite à son rêve d'enfant de devenir inventeur, le Catalan Andreu Carulla a fondé son studio de design de produits

homonyme en 2006, devenant l'une des sociétés de design les plus polyvalentes qui travaillent aujourd'hui en Espagne.

L'exploration constante des matériaux, des techniques anciennes, les processus scolaires et contemporains caractérisent les projets du studio, comprenant le mobilier, la vaisselle, l'éclairage, la mise en scène créative, les intérieurs et encore plus.

Le studio est entouré d'un lac idyllique et à une heure de Barcelone, un moulin réaménagé abrite le studio et l'atelier du designer, reflétant une approche méditerranéenne du design.

Récompenses / Récompenses

RED-DOT Best of the Best – Collection OM

BON DESIGN – Collection ALAT

## André Ricard

Il est né à Barcelone en 1929. Autodidacte, à une époque où le design n'était pas reconnu comme tel en Espagne, il effectue divers séjours en France, en Suisse et à Londres où il accumule de l'expérience. En 1958, il crée son propre studio à Barcelone : le Centre de Design Industriel (CDI). Parmi ses créations les plus emblématiques, se distinguent les récipients Agua Brava, le mixeur Moulinex, les cendriers de Copenhague ou la torche olympique Barcelona 92. Ses designs simples et fonctionnels reflètent une recherche constante de ce qu'il appelle « l'éthique et l'esthétique de l'utilitaire ». Parallèlement à son travail de designer, il a développé une activité importante pour la promotion et la reconnaissance du design, occupant des postes importants dans les groupes et associations de designers.

Récompenses / Récompenses

PRIX NATIONAL DE DESIGN 1987

CREU DE SANT JORDI GENERALITAT DE CATALOGNE

MÉDAILLE D'OR DU MÉRITE ARTISTIQUE

CHEVALIER DES ARTS ET DES LETTRES DE FRANCE

...ET DES PRIX ET RECONNAISSANCES INTERNATIONALES SANS FIN



## Serraydelarocha

Ferran Serra Solà (1975) et Oscar Vera de la Rocha (1976) sont des designers industriels de l'Escola de Disseny Elisava (Barcelone). Ils unissent leurs forces en 2002 et créent le studio scp Serrayde la Rocha en 2004.

Passion et rigueur sont leur lettre de présentation, et ils comprennent le design comme un outil essentiel améliorer et innover pour un avenir meilleur.

Son activité se concentre sur la conception de produits, conseil aux entreprises en gestion de conception, allant de la gestion du marketing, du design suivi conceptuel et d'ingénierie jusqu'à la mise en service sur le marché.

Récompenses / Récompenses

PRIX IPLUS 2009 / PRIX GIDI 2011 pour l'innovation

4 SÉLECTION AEDP / 6 SÉLECTION DELTA





## Studio Inma Bermúdez

Le Studio Inma Bermúdez est basé à Valence, en Espagne.

Fondée en 2007 par le designer industriel Inma Bermúdez, rejoint en 2009 le studio Moritz Krefter.

Notre travail se concentre principalement sur le mobilier, éclairage et accessoires, mais nous sommes toujours heureux et

curieux de nous immerger dans de nouveaux domaines. Nous développons des produits pour différentes entreprises partout dans le monde comme l'Espagne, la France, le Portugal, l'Allemagne, Suède, Inde et Colombie. Nous complétons notre travail en atelier par l'enseignement dans différentes écoles de design.

Récompenses / Récompenses

Delta 2020 – Collecte LOU

IF AWARDS – Collection LOU

PRIX NATIONAL DE DESIGN 2022

PREMIÈRE FEMME ESPAGNOLE À CONCEVOIR CHEZ IKE

## Studio Run Design

Run est un studio de design indépendant né à Barcelone en 2003.

Nous réalisons des projets de communication graphique imprimée, numérique et environnementale, destinés aux particuliers, aux entreprises, institutions et autres organisations.

Nous construisons, avec nos clients et collaborateurs, des propositions sincères et surprenantes, mais aussi discutables. Nous pensons que le spectateur a le droit de réagir à ce que nous faisons, puisque les interventions publiques doivent être discutées. Nous pensons que la seule relation possible est basée sur la confiance générée par le dialogue et le respect.

Récompenses / Récompenses

CLUB DES DIRECTEURS ARTISTIQUES D'OR  
D'EUROPE 2022

LAUS GOLD ADG-FAD 2022



## Joe Doucet

Designer, entrepreneur, inventeur et directeur créatif, Joe Doucet est l'un des talents créatifs les plus recherchés qui travaillent actuellement aux États-Unis.

Diplômé de l'Art Center College of Design, Doucet a rapidement commencé à exporter sa vision aux produits, aux mobiliers, à l'environnement et technologie, à trouver des solutions aux défis quotidiens et sociaux à travers la conception. Son travail allie habilement fonction et attrait visuel tout en transmettant du sens et un message. Doucet croit que le design et le processus de réflexion d'un designer, qui est un aspect très important, peuvent jouer un rôle plus important dans l'innovation et la résolution de problèmes, ainsi que l'esthétique. Il détient actuellement de nombreux brevets pour ses dessins et inventions.

Récompenses / Récompenses

DESIGNER DE L'ANNÉE - DEZZEN LONGLISTED

PRIX DU GOOD DESIGN - DIVERS

## *Pete Sans*



Pete Sans (Barcelone, 1947) est un designer industriel Catalan. Il a commencé ses études à la Hochschule für Gestaltung d'Ulm bien qu'il n'ait pas terminé la carrière. Après avoir travaillé dans divers secteurs, en 1971, il est en charge de la conception graphique et de l'édition du magazine de photographie expérimentale *Papel Especial*. En 1979, la société de production *Snark Design* s'intéresse à certains de ses prototypes et depuis, il se consacre au design, principalement au mobilier et à l'éclairage. En 1994, il fonde sa propre entreprise *Petesans Sistemas Integrales SL*. Ses œuvres ont reçu plusieurs prix nationaux et internationaux, dont le fauteuil *Coquette* (1987) ou la lampe *Lamparaprima* (1979).

Récompenses / Récompenses  
DELTA DE ORO 1988 – CHAISE COQUETA  
OSCAR DANS L'ÉCLAIRAGE ED1983

## *Crous Calogero*

*Francesc Crous. Diplômé en 2004 en Design Produit à l'Ecole Eina de Barcelone et complète ses études au Politecnico di Milano. Il a collaboré pendant deux ans avec Martí Guixé et en 2006 il a obtenu la bourse R+FAD octroyée par le FAD, dans le but de développer un certain projet en recherche et innovation. En 2007, il rejoint l'équipe multidisciplinaire du Roca Innovation Lab. Son travail a été présenté dans différentes expositions et publications. Il est actuellement co-fondateur du studio CrousCalogero.*

*Alessandro Calogero. Il a obtenu en 2001 un diplôme en design industriel au Politecnico de Milan. En 1997, il commence à collaborer avec différents designers de la région de Milan à l'instar de Stefano Giovannoni, Guido Venturini et Miriam Mirri. En 2003, il rejoint l'équipe du LG Design Center à Milan. En 2005, il s'installe en Espagne et à partir de 2006, il commence à travailler comme concepteur au Roca Innovation Lab de Barcelone. Il est actuellement co-fondateur du studio CrousCalogero*



Premios / Awards  
SELECCIÓN DELTA 2018  
SELECCIÓN DELTA 2014  
DELTA DE PLATA 2012



## DESIGNERS AWARDS

### *Andreu Carulla*

RED-DOT Best of the Best – OM collection  
GOOD DESIGN – ALAT collection

---

### *André Ricard*

NATIONAL DESIGN AWARD 1987  
CREU DE SANT JORDI GOVERNMENT OF CATALONIA  
GOLD MEDAL FOR ARTISTIC MERIT  
CHEVALIER DES ARTS ET DES LETTRES OF FRANCE  
...AND COUNTLESS INTERNATIONAL AWARDS AND RECOGNITIONS

---

### *Inma Bermúdez Studio*

Delta 2020 – LOU collection  
IF AWARDS – LOU collection  
NATIONAL DESIGN AWARD 2022  
FIRST SPANISH WOMAN TO DESIGN AT IKEA

---

### *Run Design Studio*

GOLD ART DIRECTOR'S CLUB OF EUROPE 2022  
LAUS GOLD ADG-FAD 2022

---

### *Joe Doucet*

DESIGNER OF THE YEAR – DEZZEN LONGLISTED  
GOOD DESIGN AWARD - VARIOUS

---

### *Pete Sans*

GOLD DELTA 1988 – COQUETA CHAIR  
OSCAR IN LIGHTING ED1983

---

### *Crous Calogero*

DELTA SELECTION 2018  
DELTA SELECTION 2014  
SILVER DELTA 2012

---

### *Serraydelarocha*

IPLUS AWARD 2009 / GIDI AWARD 2011  
4 AEDP SELECTION / 6 DELTA SELECTION







LA JUGADORA



BA-6 140

BA-21-01



Fiche technique

---

Technical file



## *FICHE TECHNIQUE/ TECHNICAL DATA*

|               |         |
|---------------|---------|
| alat alu      | 170     |
| alat modular  | 171     |
| alat daybed   | 172     |
| alat wood     | 172     |
| angle         | 173     |
| arena         | 173     |
| bolet         | 173     |
| boomerang     | 175     |
| circus        | 175     |
| coqueta       | 177     |
| cuina         | 177     |
| dorm          | 177     |
| fang          | 178     |
| lola          | 178     |
| lotus         | 178     |
| lou           | 179     |
| llum          | 180     |
| maca          | 180     |
| marea         | 181     |
| masia         | 182     |
| normal        | 183     |
| nua           | 184     |
| om            | 185     |
| om wood       | 186     |
| pepa          | 187-188 |
| ten           | 189     |
| trama & malla | 190     |
| trama wood    | 191     |
| xica & xanca  | 191     |





## alat alu | pag 106

by Andreu Carulla

|            |              | Descripción<br>Description  | Estructura<br>Frame       | Cojines<br>Cushions                                    |
|------------|--------------|---|---------------------------|--|
| <b>852</b> | N. W: 135 kg | Sofá 5 plazas con cojines<br>5 seater sofa with cushions  | Aluminium<br><br>11 white | Sunbrella<br>J236 zinc<br><br>Silvertex<br>4004 ice    |
|            |              | Un/box: 1/2<br>Box size: 306x116x78 cm<br>90x116x37 cm<br>Vol: 3,156 m <sup>3</sup><br>G.W.: 150 kg | 13 black                  | Silvertex<br>9002 carbón<br><br>Sunbrella<br>J236 zinc |





# alat modular | pag 114

by Andreu Carulla

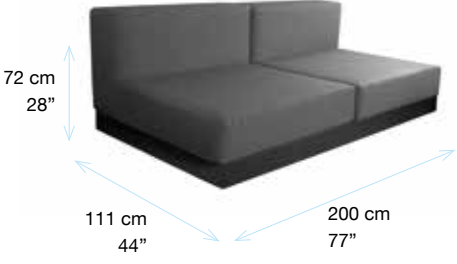
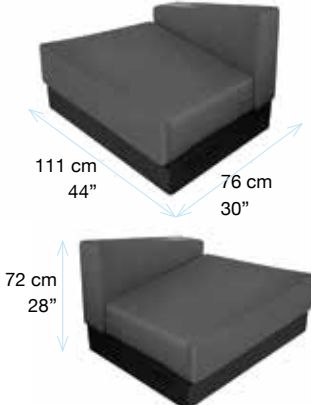
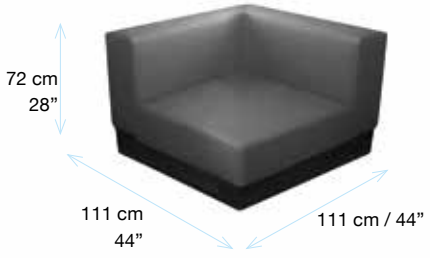
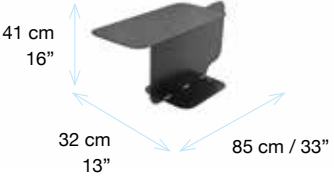
|  | Descripción<br>Description   | Estructura<br>Frame   | Cojines<br>Cushions  |
|--|--|---|--|
| <p><b>853.1</b> N.W: 70 kg</p>  <p>72 cm<br/>28"</p> <p>111 cm<br/>44"</p> <p>200 cm<br/>77"</p>                         | <p>Módulo sofá dos plazas con cojines<br/>2 seater sofa with cushions</p> <p>Un/box: 1/1<br/>Box size: 205X115X65</p> <p>Vol: 1,532 m<sup>3</sup><br/>G.W.: 85 kg</p>  | <p>Aluminium</p> <p>11 white</p> <p>13 black</p>                  | <p>Sunbrella</p> <p>J236 zinc</p> <p>Silvertex</p> <p>4004 ice</p> <p>J236 zinc</p> <p>9002 carbón</p>                                   |
| <p><b>853.3L</b> N. W: 30 kg</p> <p><b>853.3R</b></p>  <p>111 cm<br/>44"</p> <p>76 cm<br/>30"</p> <p>72 cm<br/>28"</p> | <p>Módulo alat L con cojines<br/>Módulo alat R con cojines</p> <p>Left arm with cushions<br/>Right arm with cushions</p> <p>Un/box: 1/1<br/>Box size: 89X115X64 CM</p> <p>Vol: 0,655 m<sup>3</sup><br/>G.W.: 40 kg</p> | <p>Aluminium</p> <p>11 white</p> <p>13 black</p>                  | <p>Sunbrella</p> <p>J236 zinc</p> <p>Silvertex</p> <p>4004 ice</p> <p>Sunbrella</p> <p>J236 zinc</p> <p>Silvertex</p> <p>9002 carbón</p> |
| <p><b>853.6</b> N. W: 54 kg</p>  <p>72 cm<br/>28"</p> <p>111 cm<br/>44"</p> <p>111 cm / 44"</p>                       | <p>Módulo córner con cojines<br/>Corner seater sofa with cushions</p> <p>Un/box: 1/1<br/>Box size: 117X117X75 CM</p> <p>Vol: 1,026 m<sup>3</sup><br/>G.W.: 60 kg</p>   | <p>Aluminium</p> <p>11 white</p> <p>13 black</p>                  | <p>Sunbrella</p> <p>J236 zinc</p> <p>Silvertex</p> <p>4004 ice</p> <p>Sunbrella</p> <p>J236 zinc</p> <p>Silvertex</p> <p>9002 carbón</p> |
| <p><b>853.8</b> N. W: 4 kg</p>  <p>41 cm<br/>16"</p> <p>32 cm<br/>13"</p> <p>85 cm / 33"</p>                          | <p>Mesa auxiliar<br/>Coffee table</p> <p>Un/box: 1/1<br/>Box size: 36X89X45 CM</p> <p>Vol: 0,15 m<sup>3</sup><br/>G.W.: 5 kg</p>   | <p>Aluminium</p> <p>11 white</p> <p>Aluminium</p> <p>13 black</p> | <p>HPL</p> <p>41 white</p> <p>HPL</p> <p>42 black</p>  |













## angle | pag 152

by SerradelaRocha

|  |   |   |  |
|--|---|---|--|
| <b>902</b> N.W: 178 kg<br> | <b>Descripción</b><br>Description<br>Mesa comedor<br>Dining table<br><br>Un/box: 1/5<br>Box size: 1-139x114x8 cm<br>2-117x114x8 cm<br>1-110x108x54 cm<br>1-175x96x31 cm<br><br>Vol: 3,876 m <sup>3</sup> - G.W.: 196 kg | <b>Estructura</b><br>Frame<br>Aluminium<br><br>11 white | <b>Encimera</b><br>Top<br>Dekton<br><br>ZN zenith |
|  |   | <br>19 taupe  | <br>GL galema                                     |



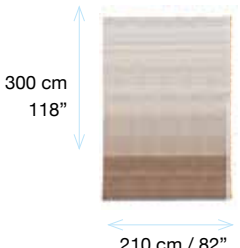

## arena | pag 7

by Andreu Carulla

|  |   |  |
|--|---|--|
| <b>194</b> N.W: 13,97 kg<br> | <b>Descripción</b><br>Description<br>alfombra<br>carpet/rug<br><br>Un/box: 1/1<br>Box size: 220x30x30 cm<br><br>Vol: 1,98 m <sup>3</sup> - G.W.: 14,15 kg | <b>Materials /</b><br>Colours<br><br>Polypropilene<br>100%<br>recycled<br><br><br>Beige |
|  |   |  |

## bolet | pag 52



by Andreu Carulla

|  |   |   |
|--|---|---|
| <b>257</b> N.W: 8,2 kg<br> | <b>Descripción</b><br>Description<br>taburete/mesa auxiliar<br>stool/side table<br><br>Un/box: 1/1<br>Box size: 45X45X48 cm<br>Vol: 0,097 m <sup>3</sup><br>G.W.: 10,2 kg | <b>Cerámica</b><br>Ceramics<br><br>GR Green 31 |
|  |   | <br>BL Blue 62                                 |
|  |   | <br>CF Coffee 24                               |
|  |   | <br>YW Yellow 52                               |

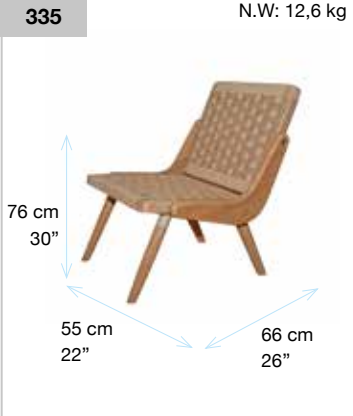

# boomerang | pag 49

by André Ricard

|   | Descripción<br>Description   | Estructura<br>Frame                                    | Acabados<br>Finishing |
|---|--|--|-----------------------|
| <p><b>335</b> N.W: 12,6 kg</p>  | <p>Relax butaca<br/>Relax chair</p> <p>Un/box: 1/1<br/>Box size: 60X70X80 cm<br/>Vol: 0,33 m<sup>3</sup><br/>G.W.: 14 kg</p> | <p>Stainless steel<br/>beige 81</p> <p>Oak wood 54</p> | <p>71 Natural</p>     |
| <p><b>336</b> N.W: 6,8 kg</p>  | <p>reposapies<br/>foot rest</p> <p>Un/box: 1/1<br/>Box size: 60X45X40 cm<br/>Vol: 0,10 m<sup>3</sup><br/>G.W.: 7,5 kg</p>    | <p>Stainless steel<br/>beige 81</p> <p>Oak wood 54</p> | <p>71 Natural</p>     |





# circus | pag 99

by Andreu Carulla

**550** N.W: 12 kg



56 cm  
22"

ø 60 cm/24"

**Descripción**  
Description

Set 3 mesas  
Set 3 tables

Un/box: 1/1  
Box size: 62x62x63 cm  
Vol: 0,242 m<sup>3</sup>  
G.W.: 13,50 kg

**Estructura**  
Frame

inox 304

11 white

14 mocca

**Acabados**  
Finishing

HPL

41 white

44 beige

**551** N.W: 5,40 kg

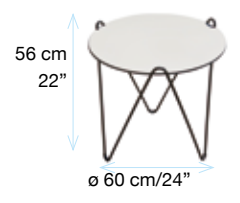

56 cm  
22"

ø 60 cm/24"

**Mesa auxiliar**  
Side table

Un/box: 1/1  
Box size: 62x62x63 cm  
Vol: 0,242 m<sup>3</sup>  
G.W.: 6,60 kg

11 white

14 mocca

41 white

44 beige

**552** N.W: 3,90 kg



46 cm  
18"

ø 50 cm/20"

**Mesa auxiliar**  
Side table

Un/box: 1/1  
Box size: 52x52x47 cm  
Vol: 0,127 m<sup>3</sup>  
G.W.: 4,90 kg

11 white

14 mocca

41 white

44 beige

**553** N.W: 2,70 kg

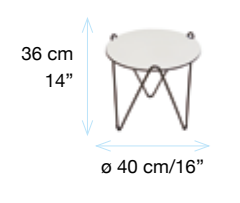

36 cm  
14"

ø 40 cm/16"

**Mesa auxiliar**  
Side table

Un/box: 1/1  
Box size: 42x42x38 cm  
Vol: 0,067 m<sup>3</sup>  
G.W.: 3,30 kg

11 white

14 mocca





41 white

44 beige

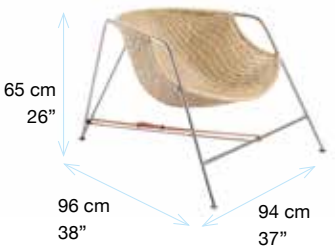

# coqueta | pag 64

by Pete Sans

|  | Descripción<br>Description  | Estructura<br>Frame   | Acabados<br>Finishing  |
|--|---|---|--|
| <p><b>341</b> N.W.: 11,6 kg</p>  | <p>original<br/>Butaca trenzada médula natural<br/>Armchair Natural wiker</p> <p>Un/box: 1/1<br/>Box size: 98X112X71 cm<br/>Vol: 0,779 m³<br/>G.W.: 15,1 kg</p> |  <p>04<br/>Stainless<br/>steel</p> |  <p>73 Natural</p> <p>Belt</p>  <p>Natural<br/>leather</p> |



# cuina | pag 26

by RUN design studio

|  | Descripción<br>Description     | Materials<br>Colours   |
|--|--------------------------------|--|
| <p><b>194</b> Cuina</p>  | <p>alfombra<br/>carpet/rug</p> | <p>Polypropilene<br/>100%<br/>recycled</p> <p> Color base</p> <p> Silver</p> |
| <p><b>194</b> Cuina</p>  | <p>alfombra<br/>carpet/rug</p> |  |





# dorm | pag 72

by SerraydelaRocha

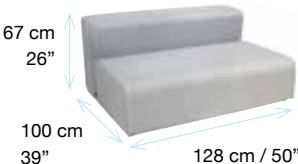
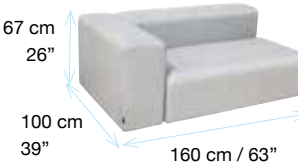
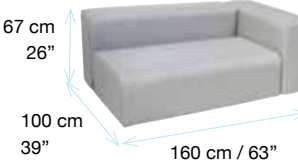
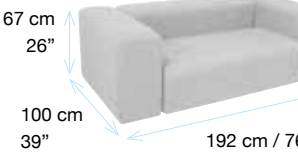
|   | Descripción<br>Description   | Tejido<br>Fabric  |
|---|--|---|
| <p><b>811</b> N.W: 42 kg</p>    | <p>Extensión 2 plazas<br/>2 seater extension</p> <p>Un/box: 1/1<br/>Box size: 131x103x66 cm<br/>Vol: 0,891 m<sup>3</sup><br/>G.W.: 51 kg</p>         | <p>Silvertex</p> <p>4004 Ice</p> <p>9190 old fashion blush</p> <p>9193 old fashion sand</p> |
| <p><b>814</b> N.W: 49 kg</p>    | <p>Meridienne brazo derecho<br/>Right arm meridienne</p> <p>Un/box: 1/1<br/>Box size: 164x103x66 cm<br/>Vol: 1,115m<sup>3</sup><br/>G.W.: 58 kg</p>  |   |
| <p><b>815</b> N.W: 49 kg</p>  | <p>Meridienne brazo izquierdo<br/>Left arm meridienne</p> <p>Un/box: 1/1<br/>Box size: 164x103x66 cm<br/>Vol: 1,115m<sup>3</sup><br/>G.W.: 58 kg</p> |   |
| <p><b>816</b> N.W: 56 kg</p>  | <p>Sofá 2 plazas<br/>2 seater sofa</p> <p>Un/box: 1/1<br/>Box size: 196x103x66 cm<br/>Vol: 1,339 m<sup>3</sup><br/>G.W.: 65 kg</p>                   |   |



Otros colores, consultar  
Ask for other colors





funda hibernación/protection cover







# fang | pag 30

by RUN design studio

|  | Descripción<br>Description | Materials /<br>Colours  |
|--|----------------------------|---|
| <b>193</b> Fang<br><br>240 cm / 94"<br>170 cm / 67" | alfombra<br>carpet/rug     | Polypropilene<br>100%<br>recycled<br>Color base<br>Silver<br>Color base<br>Salmon<br>Color base<br>Blue |
| <b>193</b> Fang<br><br>Ø 150 cm / 59"               | alfombra<br>carpet/rug     | Polypropilene<br>100%<br>recycled<br>Color base<br>Yellow   |
| <b>193</b> Fang<br><br>Ø 200 cm / 79"              | alfombra<br>carpet/rug     | Polypropilene<br>100%<br>recycled<br>Color base<br>Blue C   |



# lola | pag 103

by Andreu Carulla

|   | Descripción<br>Description  | Estructura<br>Frame  | Tejido<br>Fabric  |
|---|---|--|---|
| <b>643</b> N.W: 8 kg<br><br>84 cm / 33"<br>61 cm / 24" 48 cm / 19" | Silla comedor<br>Dining chair<br><br>Un/box: 4/1<br>Box size: 69x51x105 cm<br>Vol: 0,369 m³<br>G.W.: 34 kg | Aluminium<br><br>11 white | Batyline Eden<br><br>0567 silver<br><br>0553 blue |

# lotus | pag 23

by Pete Sans











|   | Descripción<br>Description  | Materials /<br>Colours   |
|---|---|--|
| <b>712</b><br><br>5,5 cm<br>31,5cm | lampara para piscina<br>pool lamp<br>Un/box: 1/1<br>Box size: 45x45x15 cm<br>Vol: 0,030 m³<br>G.W.: 1,70 kg |  corcho 81<br>cork 81 |



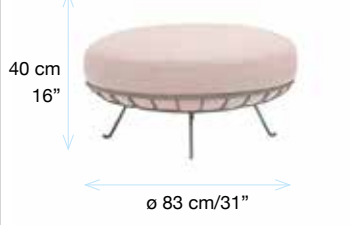

# lou | pag 58

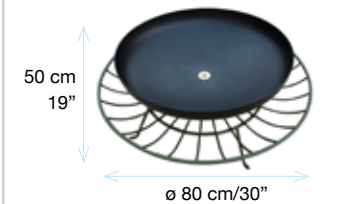
by Inma Bermudez studio

|   | Descripción<br>Description   | Estructura<br>Frame  | Tejidos<br>Fabrics  |
|---|--|--|---|
| <b>352</b> N.W: 18 kg<br> <p>62 cm<br/>24"<br/>           ø 88 cm/35"</p>                               | <b>butaca con cojines</b><br><b>armchair with cushions</b><br><br>Un/box: 1/1<br>Box size: 89X89X66 cm<br>Vol: 0,523 m <sup>3</sup><br>G.W.: 25 kg |  <p>20 Green 6003</p> | <b>Agora</b><br><br><br>Old fashion blush 9190<br><br>Old fashion sand 9193     |
| <b>353</b> N.W: 29,2 kg<br> <p>62 cm<br/>24"<br/>           148 cm/58"<br/>           83 cm<br/>33"</p> | <b>sofa con cojines</b><br><b>sofa with cushions</b><br><br>Un/box: 1/1<br>Box size: 155X89X67 cm<br>Vol: 0,924 m <sup>3</sup><br>G.W.: 37 kg      |  | <b>Agora</b><br><br><br>Old fashion blush 9190<br><br>Old fashion sand 9193     |
| <b>354</b> N.W: 12,2 kg<br> <p>40 cm<br/>16"<br/>           ø 83 cm/31"</p>                           | <b>pouf con cojines</b><br><b>pouf with cushions</b><br><br>Un/box: 1/1<br>Box size: 89X89X46 cm<br>Vol: 0,364 m <sup>3</sup><br>G.W.: 17,4 kg     |  | <b>Agora</b><br><br><br>Old fashion blush 9190<br><br>Old fashion sand 9193 |
| <b>355</b><br> <p>50 cm<br/>19"<br/>           ø 80 cm/30"</p>  | <b>brasero</b><br><b>firepit</b><br><br>Un/box: 1/1<br>Box size: 89X89X46 cm<br>Vol: 0,364 m <sup>3</sup><br>G.W.: 17,4 kg                         |  | <b>Cuenco de Acero</b><br><b>Stell vessel</b><br><br><br>black 13  |







## Cojines decorativos incluidos / Decorative cushions included

|   |   |  |
|---|---|--|
|  <p>50x50 cm</p> | <b>Butaca/Armchair</b><br> <p>AGORA Liso Oliva 3724 (50x50)<br/>(1 unit)</p> | <b>Sofa/Sofa</b><br> <p>AGORA Liso Oliva 3724 (50x50) (2 units)</p>   |
|  <p>50x35 cm</p> |  <p>AGORA Liso Natural 3702 (50x35)<br/>(1 unit)</p>                         |  <p>AGORA Liso Natural 3702 (50x35) (1 unit)</p>  |
|  <p>ø 50 cm</p>  |  <p>AGORA Panama Alga 3667 (ø 50)<br/>(1 unit)</p>                           |  <p>AGORA Panama Alga 3667 (ø 50)<br/>(1 unit)</p>  <p>AGORA Liso Natural 3702<br/>(ø 50) (1 unit)</p> |









# llum | pag 125

by Crous Calogero

|  | Descripción<br>Description  | Acabado<br>Finishing  |
|--|---|---|
| <b>701</b> N.W: 5,10 kg<br> | <b>Lámpara de exterior h85</b><br><b>Outdoor lamp h85</b><br><br>Un/box: 1/1<br>Box size: 52x52x87 cm<br>Vol: 0,230 m <sup>3</sup><br>G.W.: 6,4 kg  | <b>Polietileno PE</b> <b>Madera/Wood</b><br><br> <br>21 white natural      53 iroko |
| <b>702</b> N.W: 5,50 kg<br> | <b>Lámpara de exterior h120</b><br><b>Outdoor lamp h120</b><br><br>Un/box: 1/1<br>Box size: 62x62x122 cm<br>Vol: 0,461 m <sup>3</sup><br>G.W.: 7 kg |  <br>21 white natural      53 iroko   |

# maca | pag 35

by Andreu Carulla





|  | Descripción<br>Description  | Estructura<br>Frame  | Acabados<br>Finishing  |
|--|---|--|--|
| <b>230</b> N.W: 6,70 kg<br> | <b>hamaca</b><br><b>deck chair</b><br><br>Un/box: 2/1<br>Box size: 135x65x15 cm<br>Vol: 1,131 m <sup>3</sup><br>G.W.: 14 kg | <b>Wood</b><br><br><br>iroko 53 | <b>Toiles de soleil</b><br><b>Sunbrella</b><br> l'heure bleue K908<br> june sunset L067<br>Natural cotton<br> Uni noir 20930<br> Uni taupe 20931 |





# marea | pag 133

by Andrea Carulla  
/Joe Doucet

|   |  | Descripción<br>Description   | Estructura<br>Frame   | Acabados<br>Finishing |
|---|--|--|---|-----------------------|
| <b>223</b> <p>N.W: 15 kg</p>    | <b>loveseat</b> <p>Un/box: 1/1<br/>Box size: 122X82X93 cm<br/>Vol: 0,930 m<sup>3</sup><br/>G.W.: 22,5 kg</p> | <b>Wood</b><br><br>iroko 53 | <b>Batylne Eden</b><br><br>0567 silver<br><br>0553 blue |                       |
| <b>224</b> <p>N.W: 9,5 kg</p>  | <b>swing</b> <p>Un/box: 1/1<br/>Box size: 34X34X97 cm<br/>Vol: 0,112 m<sup>3</sup><br/>G.W.: 10,5 kg</p>     |  |   |                       |



# masia | pag 17

by Andreu Carulla















|            |                    | Descripción<br>Description   | Materials<br>/ Colours                                       |
|------------|--------------------|--|--|
| <b>195</b> | <b>BIG</b> N.W: kg | alfombra<br>carpet<br><br>Un/box: 1/1<br>Box size: cm<br>Vol: m <sup>3</sup><br>G.W.: kg |  |
|            |                    |  |  |
| <b>195</b> | <b>XL</b> N.W: kg  | alfombra<br>carpet<br><br>Un/box: 1/1<br>Box size: cm<br>Vol: m <sup>3</sup><br>G.W.: kg | Polypropilene<br>100%<br>recycled<br><br>Blue<br><br>Red<br> |
|            |                    |  |  |
| <b>195</b> | <b>L</b> N.W: kg   | alfombra<br>carpet<br><br>Un/box: 1/1<br>Box size: cm<br>Vol: m <sup>3</sup><br>G.W.: kg |  |
|            |                    |  |  |





# normal | pag 38

by Andreu Carulla

|   | Descripción<br>Description   | Materials / Colours  |
|---|--|--|
| <b>720</b><br><br>N.W: 2 kg<br>32 cm / 12"<br>ø 16 cm / 6"       | <b>lámpara inalámbrica</b><br><b>wireless lamp</b><br><br>Un/box: 1/1<br>Box size: 23X23X38 cm<br>Vol: 0,020 m <sup>3</sup><br>G.W.: 2,9 kg  | <br>BR Brown 95<br><br><br>BG Beige 10     |
| <b>721</b><br><br>ø 16 cm / 6"<br>ø 10 cm / 4"<br>10 cm / 4"     | <b>lámpara aplique de pared</b><br><b>wall lamp</b><br><br>Un/box: 1/1<br>Box size: 23X23X23 cm<br>Vol: 0,012 m <sup>3</sup><br>G.W.: 1,2 kg | <br>BR Brown 95<br><br><br>BG Beige 10     |
| <b>722</b><br><br>10 cm / 4"<br>ø 16 cm / 6"                    | <b>lámpara de techo</b><br><b>ceiling lamp</b><br><br>Un/box: 1/1<br>Box size: 23X23X23 cm<br>Vol: 0,012 m <sup>3</sup><br>G.W.: 1,2 kg      | <br>BR Brown 95<br><br><br>BG Beige 10    |
| <b>723</b><br><br>38,5 cm / 15"<br>10 cm / 4"<br>45,5 cm / 18" | <b>lámpara de techo</b><br><b>ceiling lamp</b><br><br>Un/box: 1/1<br>Box size: 23X23X50 cm<br>Vol: 0,026 m <sup>3</sup><br>G.W.: 3,6 kg      | <br>BR Brown 95<br><br><br>BG Beige 10 |
| <b>724</b><br><br>12 cm / 4 7"<br>ø 19 cm / 7,4"               | <b>lámpara de techo</b><br><b>ceiling lamp</b><br><br>Un/box: 1/1<br>Box size: 30X30X30 cm<br>Vol: 0,027 m <sup>3</sup><br>G.W.: 1,5 kg      | <br>BR Brown 95<br><br><br>BG Beige 10 |



# nua | pag 94

by Ferran Serra

**935** N.W: 9,8 kg

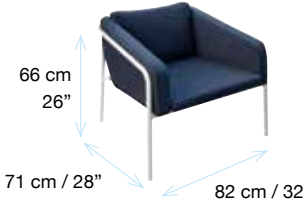

66 cm / 26"  
71 cm / 28" 82 cm / 32"

**Descripción**  
Description

Butaca con cojines  
Lounge chair with cushions

Un/box: 2/1  
Box size: 90x83x72 cm  
Vol: 0,537 m³  
G.W.: 22,6 kg

**Estructura**  
Frame

Aluminium



11 white

**Tejidos**  
Fabrics

Agora



1319 panama navy



3658 panama cloud

Silvertex



9002 carbon





# om | pag 86





by Andreu Carulla



**991** N.W: 66 kg

Parasol ø 250 cm alu/screen con base 50kg y funda  
Umbrella ø 250 cm alu/screen with 50kg base and cover

Un/box: 1/2  
Box size: 237x43x13 cm  
80x75x6 cm  
Vol: 0,173 m<sup>3</sup>  
G.W.: 79 kg



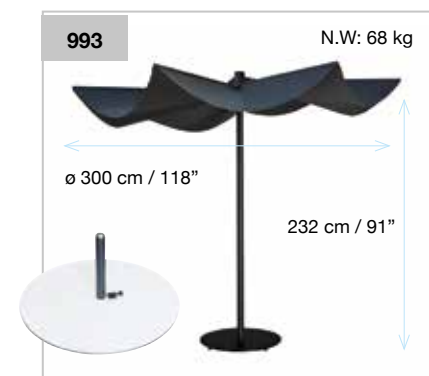

| Mastil Pole   | Cobertura Cover  |
|---|--|
| Aluminium   | Screen   |
|  13 black  |  90 black |
|  12 silver |  20 white |



**993** N.W: 68 kg

Parasol ø 300 cm alu/screen con base 50kg y funda  
Umbrella ø 300 cm alu/screen with 50kg base and cover

Un/box: 1/2  
Box size: 237x43x13 cm  
80x75x6 cm  
Vol: 0,173 m<sup>3</sup>  
G.W.: 81 kg



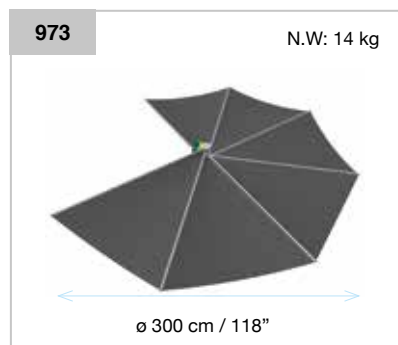

|   |  |
|---|--|
|  13 black  |  90 black |
|  12 silver |  20 white |



**973** N.W: 14 kg

Parasol de pared de 270°  
Wall umbrella 270°

Un/box: 1/1  
Box size: 162x36x17 cm  
Vol: 0,102 m<sup>3</sup>  
G.W.: 17 kg

| Top   |  |
|---|--|
|  13 black  |  90 black |
|  12 silver |  20 white |

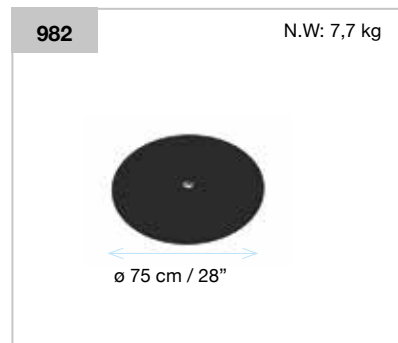



**982** N.W: 7,7 kg

Mesa auxiliar

Un/box: 1/1  
Box size: 84x84x4 cm  
Vol: 0,028 m<sup>3</sup>  
G.W.: 8,7 kg

HPL

 41 white

 42 black



**981**

Consultar para base empotrable  
Consult fixe base





 13 black

 12 silver



# om wood | pag 11

by Andreu Carulla





|  | Descripción<br>Description   | Mastil<br>Pole  | Cobertura<br>Cover  |
|--|--|---|---|
| <p><b>975</b></p>  <p>ø 250 cm / 98"</p> <p>232 cm / 91"</p> | <p>Parasol ø 250 cm de madera y cobertura acrílica con base de 50 kg y funda<br/>Umbrella ø 250 cm wood/acrylic with 50kg base and cover</p> | <p>Wood</p> <p> Iroko 53</p> | <p>Agora</p> <p> Old fashion blush 9190</p> <p> Old fashion sand 9193</p> |







# pepa | pag 78







by Andreu Carulla

|   | Descripción<br>Description   | Estructura<br>Frame   | Tejido<br>Fabric   |
|---|--|---|--|
| <p><b>543</b> N.W: 10 kg</p>  | <p>Silla comedor<br/>Dining chair</p> <p>Un/box: 4/1<br/>Box size: 60x80x100 cm<br/>Vol: 0,480 m<sup>3</sup><br/>G.W.: 42 kg</p> | <p>Inox</p>  <p>11 white</p> | <p>Agora</p>  <p>Old fashion blush 9190</p> |
|   |  | <p>14 mocca</p>              | <p>Agora</p>  <p>Old fashion sand 9193</p>  |

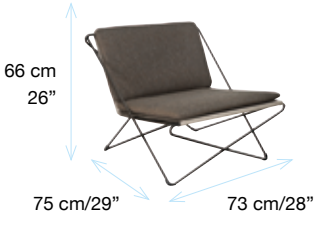
## Cojines/Cushions

|   |                          |   |
|---|--------------------------|---|
|  | <p>Cojín<br/>Cushion</p> | <p>Agora</p>  <p>Old fashion blush 9190</p>  <p>Old fashion sand 9193</p> |
|---|--------------------------|---|



|            |  | Descripción<br>Description   | Estructura<br>Frame   | Tejido<br>Fabric  | Cojín<br>Cushions  |
|------------|--|--|---|---|--|
| <b>565</b> |  <p>N.W: 12,5 kg</p> | <p>Butaca con cojín<br/>Lounge chair with cushion</p>  | <br>11 white | <p>Agora</p> <br>old fashion sand 9193 | <p>Agora</p> <br>old fashion blush 9190 |
|            |  |  | <br>14 mocca | <p>Agora</p> <br>old fashion sand 9193 | <p>Agora</p> <br>old fashion blush 9190 |
|            |  | <p>Un/box: 2/1<br/>           Box size: 78x81x77 cm<br/>           Vol: 0,483 m<sup>3</sup><br/>           G.W.: 27 kg</p> |   |   |  |





# ten | pag 157

by Calma studio

## DEKTON®

|  | Descripción<br>Description   | Estructura<br>Frame  | Encimera<br>Top   |
|--|--|--|---|
| <p><b>925</b> N.W: 65 kg</p>  <p>74 cm / 30"<br/>90 cm / 35" 240 cm / 94"</p>  | <p>Mesa comedor<br/>Dining table</p> <p>Un/box: 1/1<br/>Box size: 250x100x12 cm<br/>Vol: 0,300 m<sup>3</sup><br/>G.W.: 70 kg</p> | <p>Steel</p> <p>11 white</p> <p>13 black</p> <p>14 mocca</p> | <p>Ceramic</p> <p>AU aura</p> <p>TR trilium</p> <p>ED edora</p> |
| <p><b>924</b> N.W: 51 kg</p>  <p>74 cm / 30"<br/>90 cm / 35" 200 cm / 79"</p> | <p>Mesa comedor<br/>Dining table</p> <p>Un/box: 1/1<br/>Box size: 210x100x12 cm<br/>Vol: 0,252 m<sup>3</sup><br/>G.W.: 56 kg</p> | <p>11 white</p> <p>13 black</p> <p>14 mocca</p>              | <p>AU aura</p> <p>TR trilium</p> <p>ED edora</p>                |
| <p><b>923</b> N.W: 28 kg</p>  <p>74 cm / 30"<br/>90 cm / 35" 90 cm / 35"</p> | <p>Mesa comedor<br/>Dining table</p> <p>Un/box: 1/1<br/>Box size: 100x100x12 cm<br/>Vol: 0,120 m<sup>3</sup><br/>G.W.: 30 kg</p> | <p>11 white</p> <p>13 black</p> <p>14 mocca</p>              | <p>AU aura</p> <p>TR trilium</p> <p>ED edora</p>                |



# trama-malla | pag 140

by Andreu Carulla

Descripción

258



trama celosía cerámic natural

259



malla cerámic brick (cuadrado)

259



malla finish cerámic brick (cuadrado)

259



malla cerámic brick (redondo)

259



malla finish cerámic brick (redondo)





## trama wood | pag 146

by SerraydeLaRocha

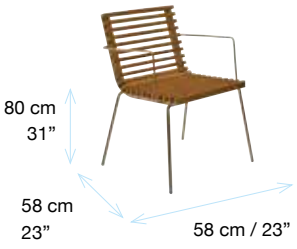
| 120  | N.W: 7,9 kg | Descripción<br>Description  | Estructura<br>Frame                      | Acabado<br>Finishing |
|--|-------------|---|--|----------------------|
|  |             | <p>Sillón / Armchair</p> <p>Un/box: 2/1<br/>Box size: 61x71x100 cm<br/>Vol: 0,433 m<sup>3</sup><br/>G.W.: 21 kg</p> | <p>04 inox /<br/>Stainless<br/>steel</p> | <p>53 iroko</p>      |

## xica | pag 130

by Crouscalogero

| 703   | N.W: 1,2 kg | Descripción<br>Description   | Acabado<br>Finishing   |  |
|---|-------------|--|--|--|
|  |             | <p>Lámpara de exterior h32<br/>Outdoor lamp h32</p> <p>Un/box: 1/1<br/>Box size: 29X29X34 cm<br/>Vol: 0,029 m<sup>3</sup><br/>G.W.: 1,8 kg</p> | <p>Polietileno PE      Madera/Wood</p> <p>21 white natural      53 iroko</p> |  |

## xanca | pag 130

by Crouscalogero

| 704  | N.W: 1,8 kg | Descripción<br>Description   | Acabado<br>Finishing   |  |
|--|-------------|--|--|--|
|  |             | <p>Lámpara de exterior h96<br/>Outdoor lamp h96</p> <p>Un/box: 1/1<br/>Box size: 34X34X96 cm<br/>Vol: 0,111 m<sup>3</sup><br/>G.W.: 3 kg</p> | <p>Polietileno PE      Madera/Wood</p> <p>21 white natural      53 iroko</p> |  |



# Tejidos/Fabrics

## AGORA **(agora)**



Agora panama  
cloud 3658



Agora panama  
navy 1319



Old fashion blush  
9190



Old fashion sand  
9193



Panama alga  
3667



Liso natural  
3702



Liso Oliva  
3724



Bruma  
1003

**Agora Fabrics** utiliza en toda su gama la fibra 100% solution dyed. Tejidos fabricados para soportar las duras condiciones del exterior, incorporando múltiples cualidades y tratamientos para hacer frente a los entornos más exigentes garantizando un rendimiento excelente. Agora es la solución IN & OUT.

**Agora Fabrics** uses 100% solution-dyed acrylic fibre throughout its range. Fabrics made to withstand harsh outdoor conditions, incorporating multiple qualities and treatments to cope with the most demanding environments and ensuring excellent performance. Strength, quality, durability, easy care and incomparable resistance to fading and degradation. Agora® fabrics also have a 5-year warranty against fading due to exposure to sunlight. These features make Agora® the perfect solution for outdoor and indoor use.

## BATYLINE

**Serge Ferrari**



Batyline Eden  
blue 0553



Batyline Eden  
silver 0567

## TOILES DE SOLEIL



Sunbrella  
June sunset L067



Sunbrella  
L'heure bleue K908



Cotton  
Uni taupe 20931



Cotton  
Uni noir 20930

## SILVERTEX



Silvertex  
carbon 9002

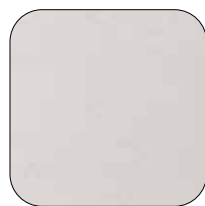

Silvertex  
ice 4004

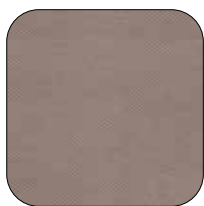

Silvertex  
taupe 0009

## RECASENS 7000P



White 000



Black 700

## SUNBRELLA

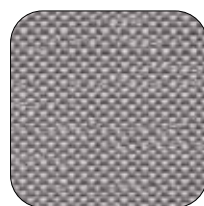

Sunbrella savanne  
zinc J236

## ALFOMBRAS / RUGS



Trenzado a mano  
100% botellas de plástico recicladas  
Aptas para exterior

Hand Knotted Sumac  
100% recycled from polypropilene bottles  
Outdoor proof





Texturado al horno / Textured powder coating



Aluminio  
black



Aluminio  
mocca



Aluminio  
taupe Ral 7006



Aluminio  
white



Aluminio  
green Ral 6003

## CERAMICA / CERAMIC



Ceramic Blue  
BL 62



Ceramic Yellow  
YW 52



Ceramic Green  
GR 31



Ceramic Coffee  
CF 24



Ceramic Beige  
BG 10



Ceramic Brown  
BR95

## TOP CERAMIC DEKTON



AU Aura

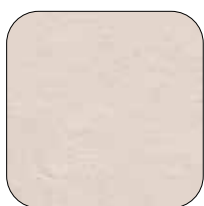

ED Edora



TR Trilium



ZN Zenith

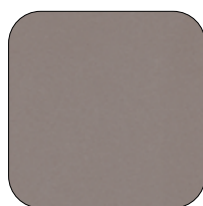

GL Galema

## MEDULA / WICKER



73 Natural Médula

## CORCHO / CORK



81 Corcho/Cork

## HPL

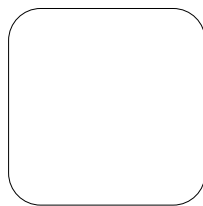

White 41

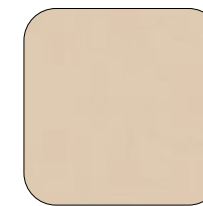

Beige 44

## MADERA / WOOD



53 Iroko wood



54 Oak wood

## ANODIZED ALUMINIUM

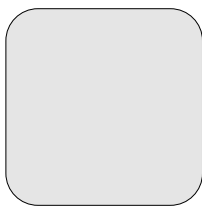

Aluminio  
12 silver

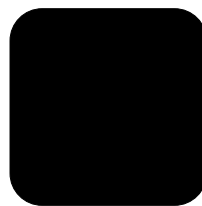

Aluminio  
13 black

ONLY ON  
COLLECTION

# (agora)<sup>®</sup>

En los tejidos Agora<sup>®</sup>, los pigmentos impregnan la disolución del polímero antes de formar la fibra. De esa manera, el hilo está tintado hasta el núcleo, lo que le confiere una excelente solidez del color y un comportamiento excepcional en condiciones exteriores y en presencia de microorganismos.

In Agora<sup>®</sup> fabrics, colour pigments impregnate the polymer dissolution before the fibre is formed. That way, the yarn is dyed to the core, conferring an excellent colour fastness and exceptional behaviour in outdoor conditions and in the presence of micro-organisms.

Tejidos Agora<sup>®</sup>  
Agora<sup>®</sup> fabrics

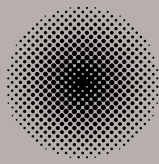

100% Acrílico tintado en masa  
100% Solution Dyed Acrylic

Otras telas  
Other fabrics

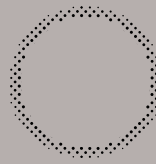

Tintura en hilo  
Yarn Dyed Process

## Cualidades / Qualities



HIDROFUGO  
WATER RESISTANT



ANTIMANCHAS  
STAIN RESISTANT



ANTIMOHO  
MOULD RESISTANT



PROTECCION UV  
UV PROTECT



RESISTENCIA UV  
UV RESISTANT



DURADERO  
DURABLE STRONG



NO CONDUCTOR  
NO CONDUCTOR



FÁCIL DE LIMPIAR  
EASY TO CLEAN



DESINFECTABLE  
DISINFECTABLE



SUAVE  
SOFT



TRANSPIRABLE  
BREATHABLE



ESTABILIDAD DIMENSIONAL  
DIMENSIONAL STABILITY



PET FRIENDLY  
APTO PARA ANIMALES

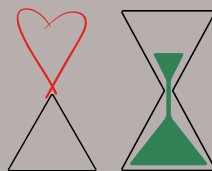

BLEACH friendly DURABLE is green



KID PROOF  
A PRUEBA DE NIÑOS



DEL CONCEPTO A LA EXPERIENCIA  
Concepts fue creado para unir los tejidos  
Agora en una solución integral para  
espacios exteriores e interiores.  
Cada concepto tiene una paleta inspirada  
en una gama cromática que te hace  
experimentar diferentes ambientes y  
escenarios mientras te anima a crear tus  
propias ideas únicas.



FROM CONCEPT TO EXPERIENCE  
Concepts was created to bring together  
Agora fabrics to a comprehensive  
solution for exterior and interior spaces.  
Each concept has a palette inspired  
by a chromatic range that makes you  
experience different moods and settings  
while encouraging you to create your  
own unique ideas.

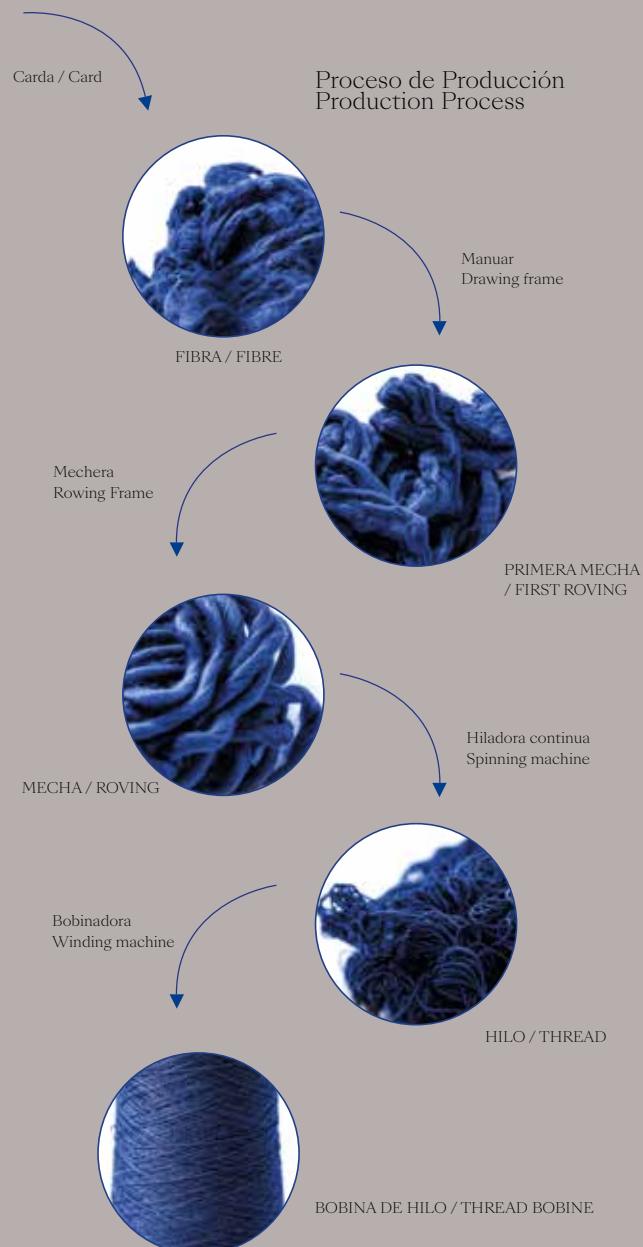

MEDITERRANEAN  
OUTDOOR FURNITURE  
ALT EMPORDÀ, GIRONA

AVDA. EUROPA 22  
POLÍGON INDUSTRIAL  
EMPORDÀ INTERNACIONAL  
17469 VILAMALLA-SPAIN

CONTACT  
T.+34 972 527 089  
INFO@CALMAOUTDOOR.COM  
CALMAOUTDOOR.COM

INSTAGRAM  
@CALMAOUTDOOR  
#LIFEWITHCALMA

calma.

